

# NEMESYS<sup>®</sup> MID PRESSURE

## Mid Pressure Module

### Features

The neMESYS Mid Pressure module is a pulsation-free dosing unit for high-precision dosing of fluid streams for applications with higher pressures.



### Dosing Performance with stainless steel syringes

Pusher Velocity min (mm/s)	26,292
Pusher Velocity max (mm/s)	4,664
Pusher Force max. (N)	1000
<b>Syringe 2,5 ml / 49,99 mm stroke</b>	
Flow Rate min (nl/min)	78,898
Flow Rate max (ml/min)	13,996
Dosing Vol. min (nl) = 1 step	0,858
Reachable Pressure (bar)*	198,94
<b>Syringe 10 ml / 49,99 mm stroke</b>	
Flow Rate min (µl/min)	0,316
Flow Rate max (ml/min)	56,089
Dosing Vol. min (nl) = 1 step	3,437
Reachable Pressure (bar)*	49,73
<b>Syringe 25 ml / 50,86 mm stroke</b>	
Flow Rate min (µl/min)	0,775
Flow Rate max (ml/min)	137,545
Dosing Vol. min (nl) = 1 step	8,428
Reachable Pressure (bar)*	20,37
<b>Syringe 50 ml / 51,91 mm stroke</b>	
Flow Rate min (µl/min)	1,519
Flow Rate max (ml/min)	269,533
Dosing Vol. min (nl) = 1 step	16,516
Reachable Pressure (bar)*	10,39

\*The pressure values valid for the use of stainless steel syringes by cetoni.  
Available seal materials for stainless steel syringes are FKM, EPDM, NBR

### Mechanical Data

Weight ..... 1,8 kg  
Dimensions (L x W x H) ..... 310 x 69,5 x 99,3 mm

### Electrical Data

Power Supply Voltage ..... 24 VDC  
Dosing Unit Current typical at 24 VDC ..... 0.4 A  
Dosing Unit Current peak at 24 VDC ..... 1 A

### Environment

Operating Temperature ..... 0°C to 45°C  
Storage Temperature ..... -40°C to 75°C  
Operating Humidity ..... 20% to 80%, non-condens.  
Storage Humidity ..... 20% to 80%, non-condens.

### Interfaces

CAN ..... max. 1 Mbit / s  
RS-232 ..... max. 115200 bit/s

### Configuration

3-Way-Valve ..... optional  
Syringes outer diameter ..... 6 to 25 mm  
Syringes Stroke ..... 62 mm  
Syringe types ..... glass or stainless steel  
Steel Syringe volumes (ml) ..... 2.5, 10, 25, 50

### Valve

Body material ..... PEEK  
Seal material ..... FFKM  
Max. Valve Pressure ..... 130 bar / 1885 psi  
Temperature media ..... 10 to +100°C  
Internal Volume ..... < 50 µl  
Orifice ..... DN 1.0 or 1.5 mm  
Port connection ..... Flange, UNF 1/4"-28

### Mechanical Drawing

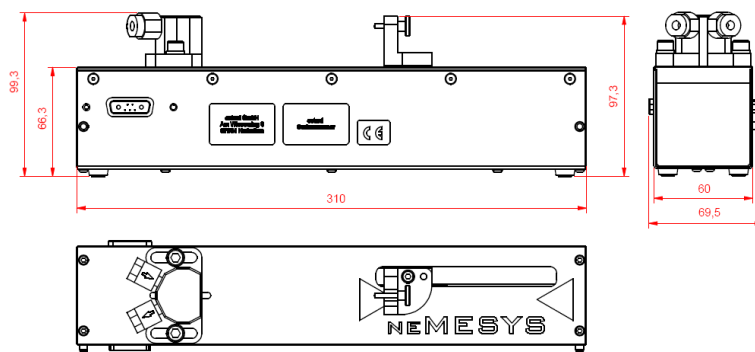

You can choose between glass syringes and stainless steel syringes for your application.



10/03/09

cetoni GmbH  
Am Wiesenring 6  
07554 Korbussen  
Germany

Phone: +49 36602 338 0  
Fax: +49 36602 338 11  
Email: info@cetoni.de  
[www.cetoni.de](http://www.cetoni.de)

