

NEMIX

April 2009

Manual

Stirring Bottle

 **cetoni**[®]

The information and data contained in this document may be changed without prior notice. No part of this document may be duplicated or transmitted for any purpose, irrespective of the method or means – electronic or mechanical – used for duplication or transmission without the express written authorisation of cetoni GmbH.

The General Terms and Conditions of cetoni GmbH shall apply. Agreements deviating from these General Terms and Conditions shall require the written form for their validity.

Copyright © cetoni GmbH – Automation and Microsystems. All rights reserved

Licence agreement

cetoni GmbH grants the Buyer the simple, non-exclusive and non-transferable licence to use the software on a single computer or networked computer system (LAN). Copying or any other form of duplication of the software, in whole or in part, as well as mixing and combining with other software is expressly forbidden. The Buyer may make one single copy of the software for his own backup purposes. cetoni GmbH reserves the right to modify, further develop and/or improve the software or to replace the software with a new development. cetoni is under no obligation to inform the Buyer about modifications, new developments, further developments or improvements, or to make such available to the Buyer. No legally binding assurance of given properties is given. cetoni assumes no liability for damage unless such damage is caused by intent or gross negligence on the part of cetoni GmbH or of its sub-contractors and vicarious agents. Any liability for indirect and for incidental and consequential damages is excluded.

Revision 1.0



cetoni GmbH
Am Wiesenring 6
D-07554 Korbußen
Tel.: +49 (0) 36602 338-0
Fax: +49 (0) 36602 338-11

E-mail: info@cetoni.de
Internet: www.cetoni.de

1 Overviews and Indices

1.1 Table of contents

1 Overviews and Indices	4
1.1 Table of contents.....	4
1.2 Revision history.....	6
2 Safety Precautions	7
2.1 Symbols and signal words used	7
2.2 Standards and directives.....	7
3 Fundamental Information	8
3.1 Foreword	8
3.2 Purpose	8
3.3 Intended use	9
3.3.1 Safety measures	9
3.3.2 Measures for safe operation	10
3.3.3 Safety installations on the appliance	10
3.3.4 Condition of the appliance	10
3.4 Warranty and liability.....	11
3.5 Scope of supply.....	12
4 Technical Data	13
4.1 Mechanical data	13
4.2 Electrical data.....	13
4.3 Environment	13
4.4 Configuration.....	13
4.5 Stirring capacity.....	14
5 Commissioning	15
5.1 Connection to the syringe pump	15
5.2 Filling, bleeding and dosing.....	16
5.2.1 Carrier medium lighter than particle suspension	16
5.2.2 Particle suspension lighter than carrier medium.....	19
5.3 Valves and refilling the syringe	22
6 Shutting Down	23
6.1 Cleaning	23
6.2 Dismantling of the stirring bottle.....	23

6.3	Assembly of the stirring bottle	25
7	Transport and Storage	26
7.1	Transport	26
7.2	Storage	26
8	Troubleshooting.....	27
9	Maintenance and Care	28

1.2 Revision history

Rev.	Date	Revision
1.0	27.04.2009	<ul style="list-style-type: none">• Creation of manual (Christine Naber)

2 Safety Precautions

2.1 Symbols and signal words used

The following symbols are used in this manual and are intended to assist you in the navigation through this document:



IMPORTANT

Signals operating tips and other particularly useful information, whereby no hazardous or damaging situations occur.



ATTENTION

Signals a potentially damaging situation. If this situation is not avoided, the product or something in its vicinity may be damaged.



CAUTION

Signals a potentially hazardous situation. If the situation is not avoided, slight or minor injuries and equipment damage may result.

2.2 Standards and directives



This appliance has been tested and approved for compliance with the limit values for industrial apparatus of Class 1, Group B.

Operation is subject to the following conditions:

1. The appliance must not cause any harmful parasitic radiation.
2. The appliance must be able to process parasitic radiation, including such radiation that could result in an undesirable operation.

3 Fundamental Information

3.1 Foreword

Thank you for choosing a product from cetoni. This user manual is intended to provide you with the best possible assistance in using the neMIX stirring bottle.

You should put the neMIX stirring bottle into operation only after thorough reading of the present manual. We wish you every success in your work with the neMIX stirring bottle.

3.2 Purpose

The appliance is intended for thorough mixing of particle suspensions and helps to prevent sedimentation. That permits the dosage or homogeneous concentrations over long periods, an aspect of great importance in many chemical and biological processes.



IMPORTANT

The stirring of magnetic beads is not possible with this system as a magnetic stirring principle is involved.

3.3 Intended use

3.3.1 Safety measures

The safety of the operator and trouble-free operation of the appliance are only assured when original equipment parts are employed. All warranty claims will be voided in the event of damage caused by the use of third-party accessories or third-party consumables.



IMPORTANT

The appliance must not be used as a medical product or for medical purposes.

The appliance has been developed and built in such a way that hazards during the intended use can be effectively ruled out. Nevertheless, the following safety measures should be observed to avoid any residual hazards.

- The laws and regulations applicable at the place of use must be observed during operation of the appliance! In the interests of a safe working procedure, owners and operators are equally responsible for compliance with the regulations.
- The user must inspect the appliance for functional safety and proper condition before any use of the appliance.
- The user must be familiar with the operation of the appliance.
- Appliance and lines must be inspected for damage before using for the first time. Damaged lines and plug connectors must be replaced immediately.
- All cables must be laid in such a way that they do not pose a tripping hazard.
- Observe the following when working with inflammable or explosive substances: The appliance has no ex-proof installations. Use of the appliance in explosive atmospheres is forbidden!

3.3.2 Measures for safe operation

Electromagnetic emissions

The neMIX stirring bottle is intended for use in all facilities, including those in residential areas and those connected directly to a public supply grid that also supplies buildings used for residential purposes.

Electrostatic discharges (ESD)

Floors should be of wood or concrete, or should be covered with ceramic tiles. If the floor is covered with synthetic material, the relative humidity must be at least 30%.

Electrical interference

The quality of the supply voltage should correspond to that of a typical business or hospital environment.

Magnetic interference

Do not install power lines or other apparatus in the vicinity of the appliance. Portable and mobile radios should not be used closer to the appliance and its lines than the recommended safety distance!

3.3.3 Safety installations on the appliance

In an emergency, the appliance can be switched off by pressing on the rotary controller or by disconnecting the power pack; this does not cause any damage to the appliance.

3.3.4 Condition of the appliance

Despite the most careful production of the appliance, it may be damaged during use. A visual inspection of the components should therefore be carried out before every use. Pay particular attention to pinched cables, damaged hoses or deformed plug connectors. Should you discover any damage, please do not use the appliance and contact cetoni GmbH immediately; cetoni will ensure that your appliance is returned to a serviceable condition as quickly as possible. On no account try to carry out repairs to the appliance yourself.

Opening of the appliance will void all guarantee or warranty claims.

3.4 Warranty and liability

The present appliance left our company in perfect condition. The appliance may only be opened by the manufacturer. If the appliance is opened by unauthorised persons, all guarantee and liability claims will be voided, in particular claims for damages in the event of personal injury.

The warranty period is 1 year from the date of delivery. It is not prolonged or renewed by work carried out under warranty.

cetoni GmbH considers itself responsible for the safety, reliability and function of the appliance only if installation, settings, modifications, expansions and repairs are carried out by cetoni GmbH or by an authorised body and if the appliance is operated in accordance with the user manual.

The neMIX stirring bottle confirms to the fundamental safety engineering standards. We reserve all property rights to circuits, processes, names, software programs and appliances mentioned in this manual

3.5 Scope of supply

The scope of supply of your stirring bottle includes the following components:

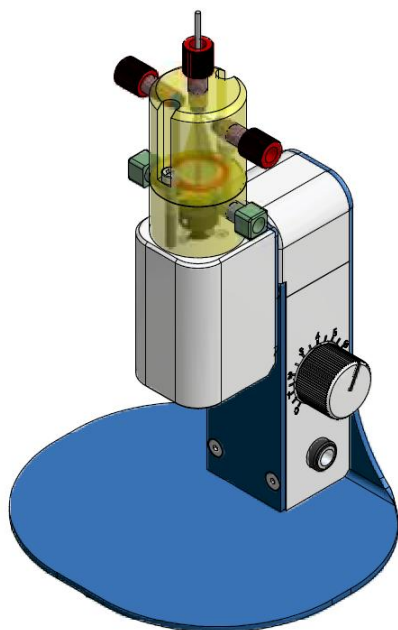

Stirring bottle



Plug-in power supply unit



4 shut-off needles

Two replacement stirring clappers



IMPORTANT

The neMESYS syringe pump system is required for operation of the neMIX stirring bottle!

4 Technical Data

4.1 Mechanical data

Weight of the stirring bottle approx. 510 g

Dimensions (L x W x H) 120 x 103 x 198 mm

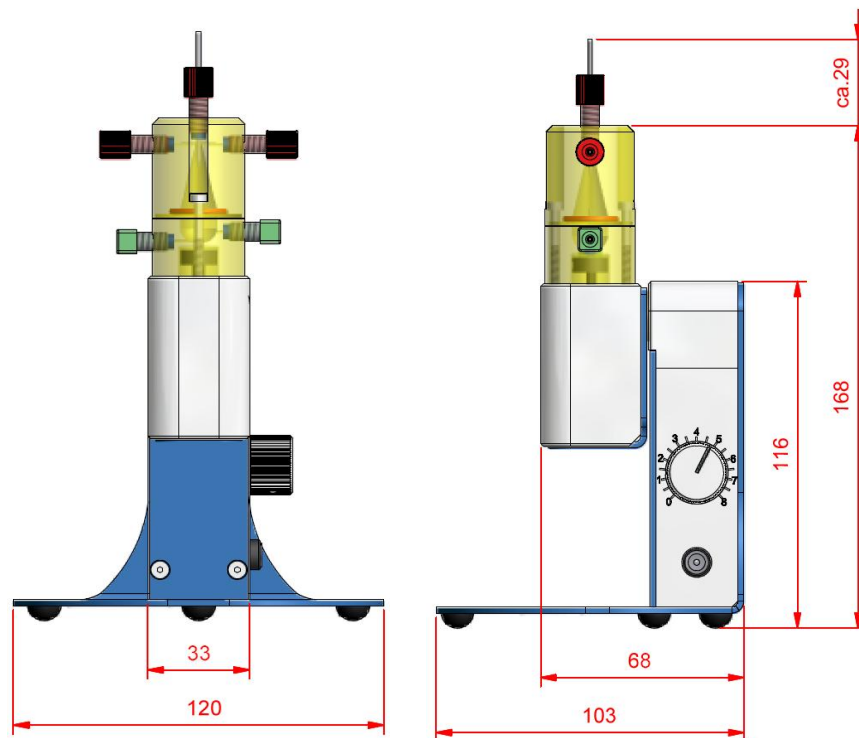

4.2 Electrical data

Operating voltage..... 24 VDC

4.3 Environment

Working temperature0°C to 45°C

Storage temperature-40°C to 80°C

Working humidity20% to 80%, non-condensing

Storage humidity20% to 80%, non-condensing

4.4 Configuration

Inside volume 1.9 ml

Min. stirring speed 14.2 rpm
Max stirring speed 426.6 rpm
Compatible hosesID 0.8 mm, OD 1.6 mm

4.5 Stirring capacity

The following diagram shows the speed of the stirrer (in upm) as a function of the rotary controller position.

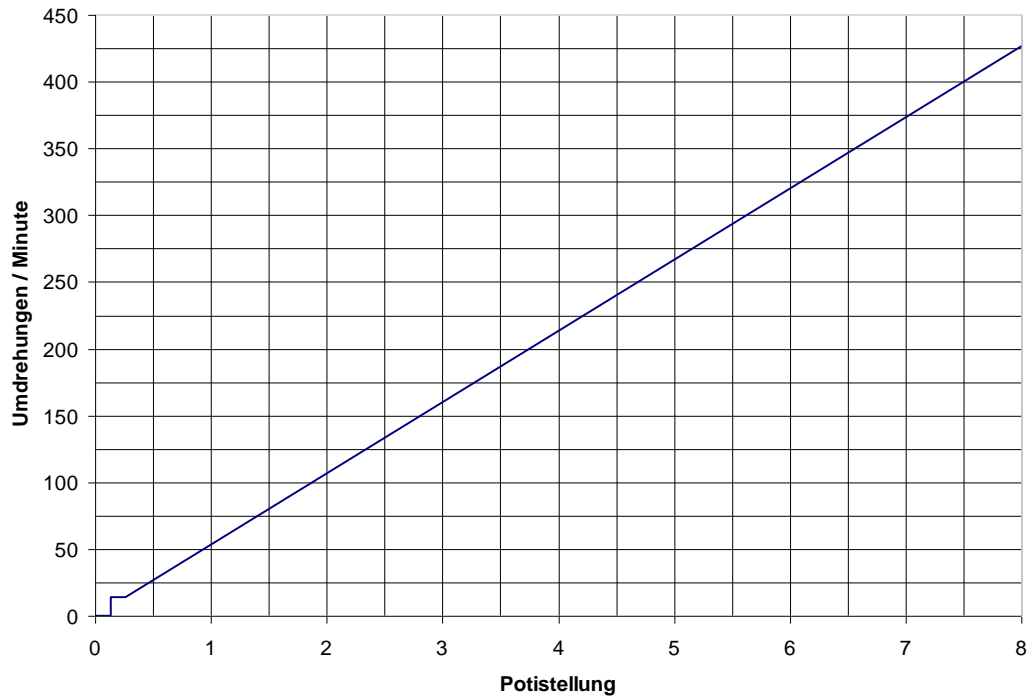

5 Commissioning

5.1 Connection to the syringe pump

There are two different starting situations for the operation of the stirring bottle:

- Situation 1: The carrier medium has a lower density than the suspension to be mixed
- Situation 2: The carrier medium has a higher density.

Should situation 1 exist, install the stirring bottle and connect the hoses as shown in Fig. 1. The configuration for situation 2 is illustrated in Fig. 2.

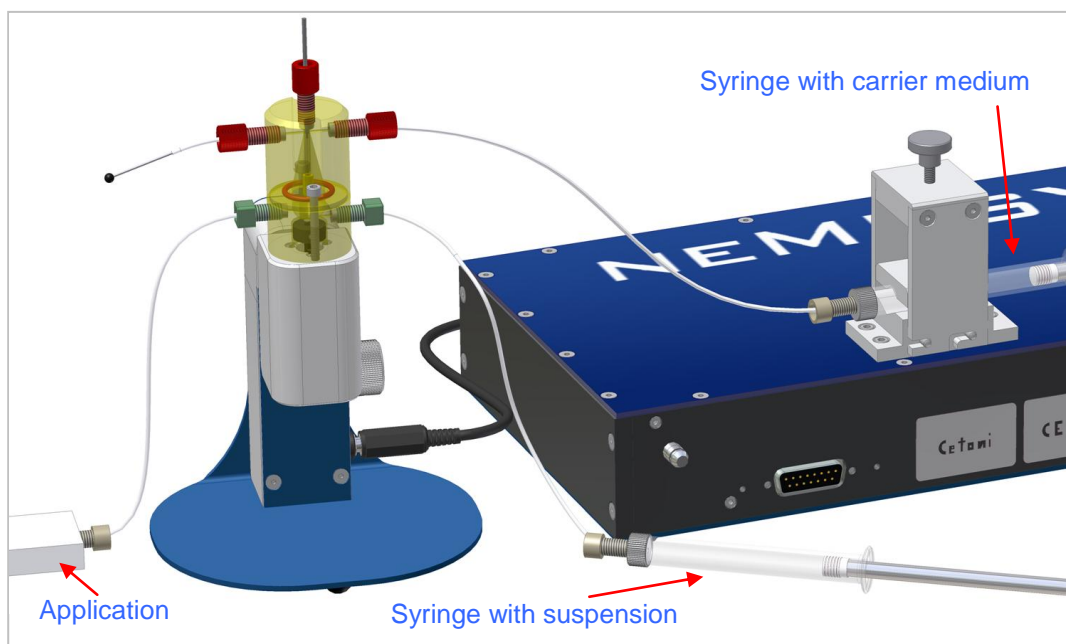

Figure 1: Carrier medium with lower density than the suspension

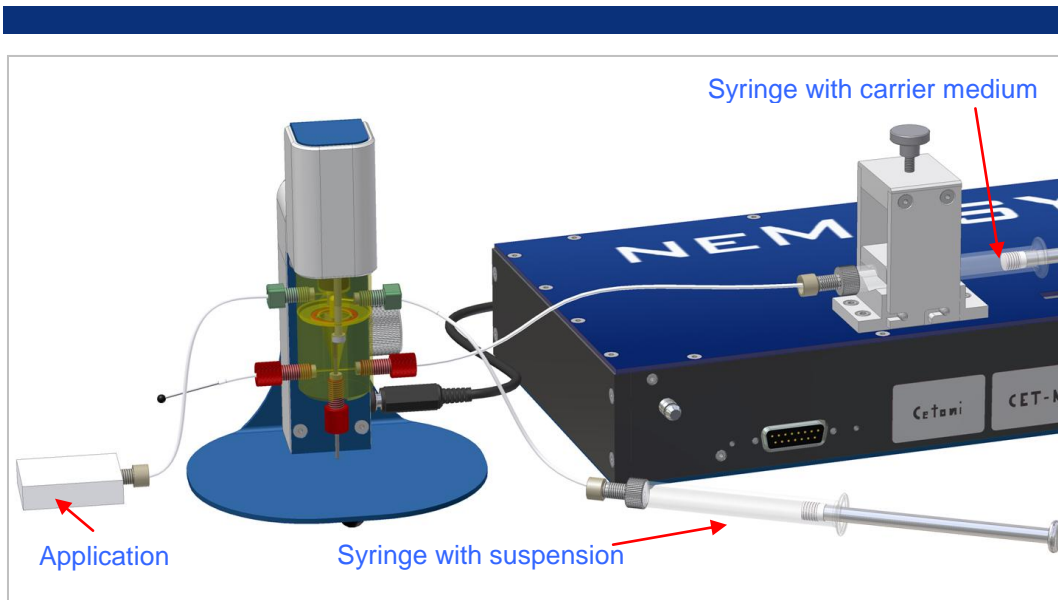
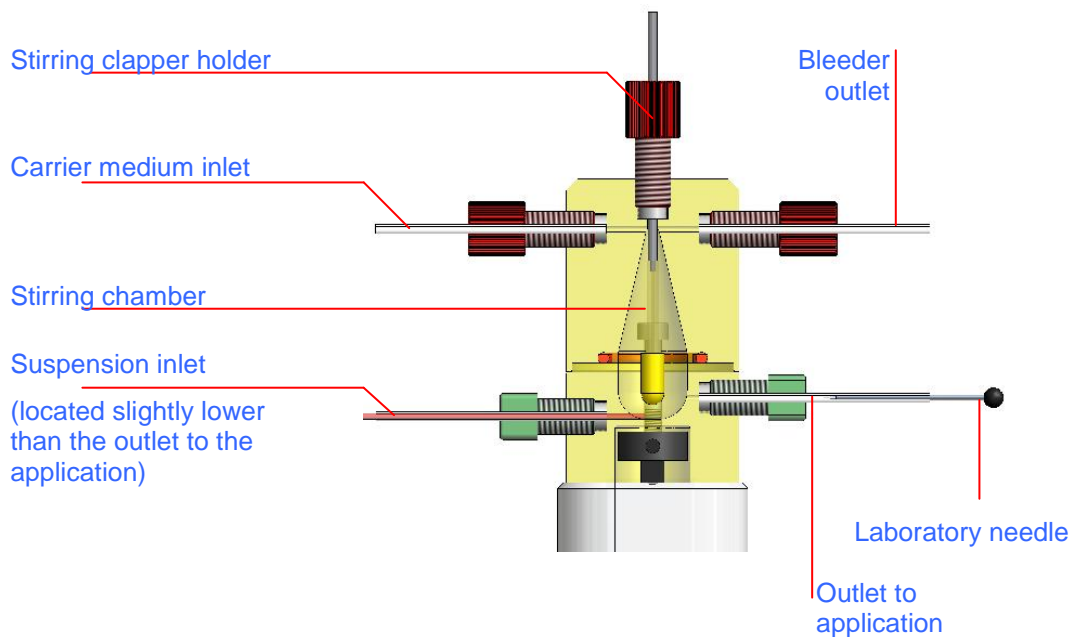

Figure 2: Carrier medium with higher density than the suspension

5.2 Filling, bleeding and dosing

5.2.1 Carrier medium lighter than particle suspension



Starting situation:

The two inlets are stopped. The outlet to the application is closed with a laboratory needle and the bleeder outlet is free.

The stirrer is switched off.

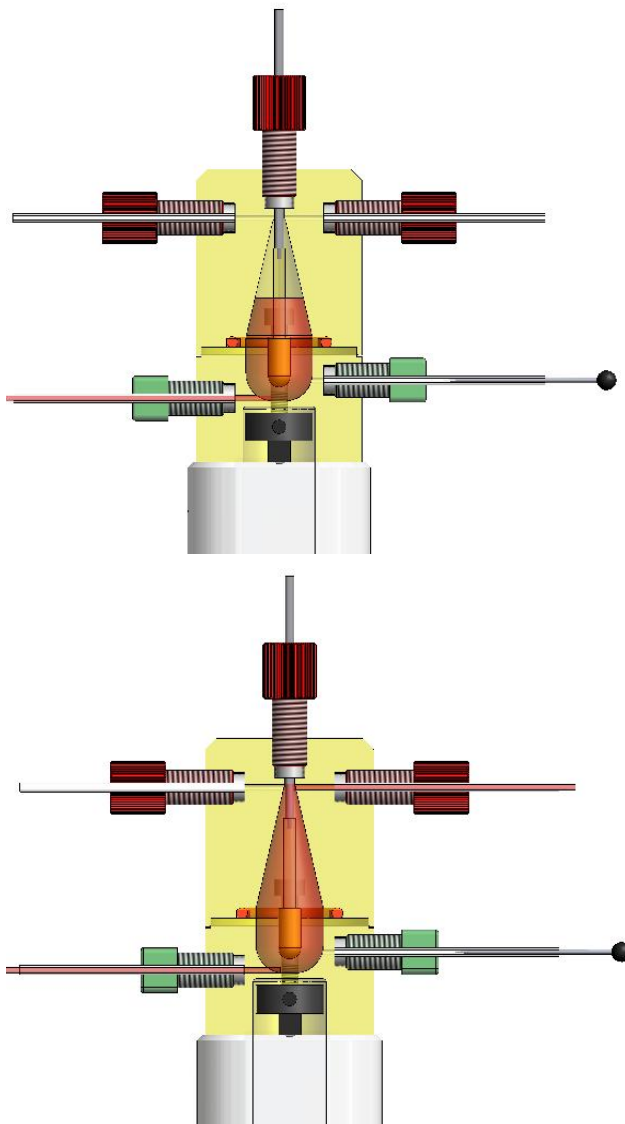

Step 1:

Start by filling the bottle with the particle suspension. This can be performed manually using a syringe, or by using the neMESYS syringe pump.

Step 2:

Fill the stirring bottle until the suspension overflows from the bleeder outlet. The stirring bottle has an inside volume of 1.9 ml.

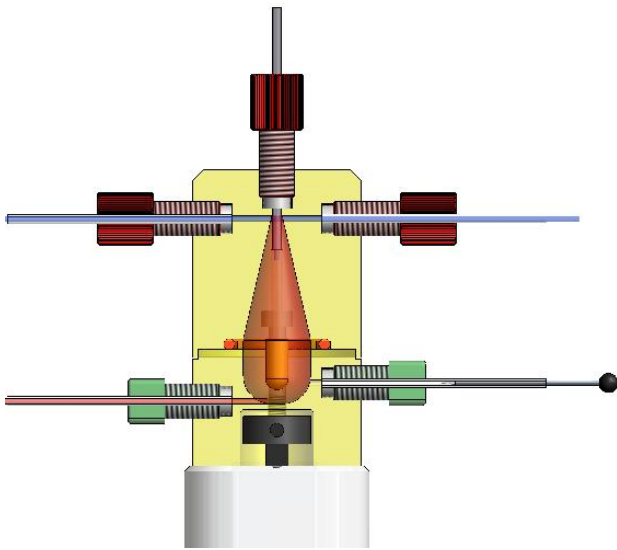

Step 3:

Slowly add the carrier medium via the upper inlet using the neMESYS syringe pump until it overflows from the bleeder outlet.

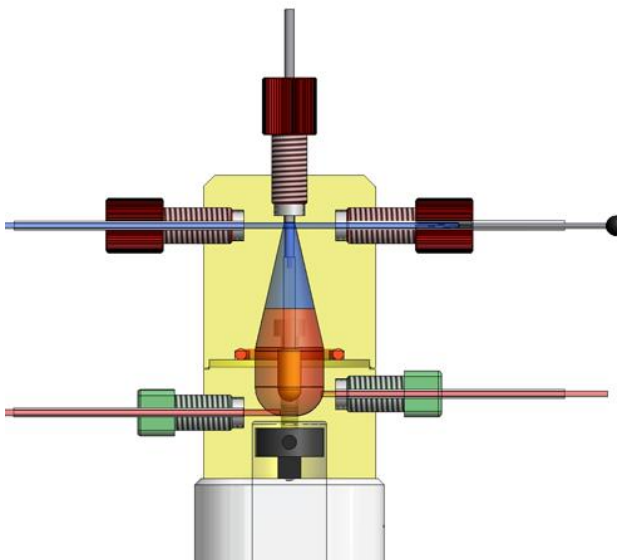

Step 4:

Close the bleeder outlet using a laboratory needle.

Then remove the laboratory needle from the outlet to the application.

You can now switch on the stirrer motor by pressing the rotary controller.

You are now in a position to deliver your suspension precisely into the application by dosing the carrier medium.

The stirring process is stopped by pressing the rotary controller.

5.2.2 Particle suspension lighter than carrier medium

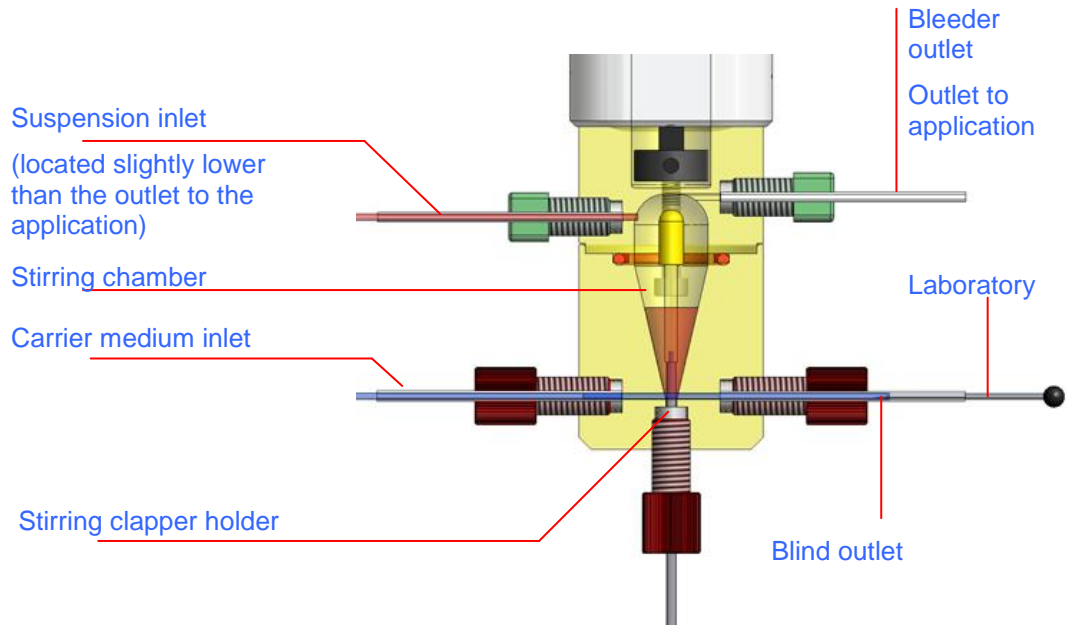

Proceed as follows to operate your neMIX stirring bottle with a carrier medium that is heavier than the particle suspension, i.e. on which the particle suspension 'swims'.

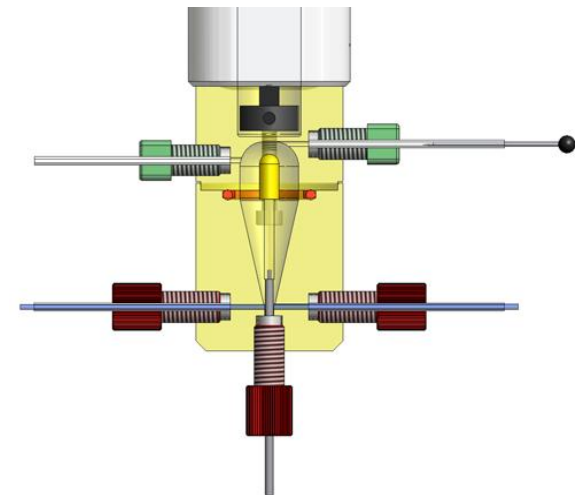

Step 1:

The bleeder outlet / outlet to the application is closed with a laboratory needle, the blind outlet is open.

Dose the carrier medium (blue) until a droplet emerges from the blind outlet.

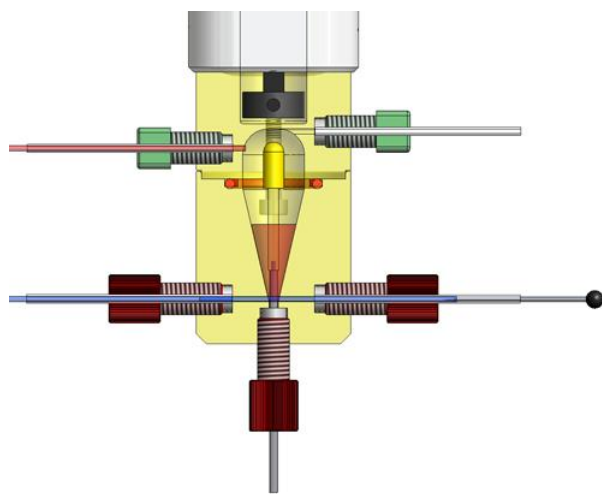

Step 2:

Close the blind outlet using a laboratory needle so that no air can enter the hose, i.e. pierce the emerging droplet with the laboratory needle.

Remove the needle from the bleeder outlet / outlet to the application and start dosing the suspension (red).

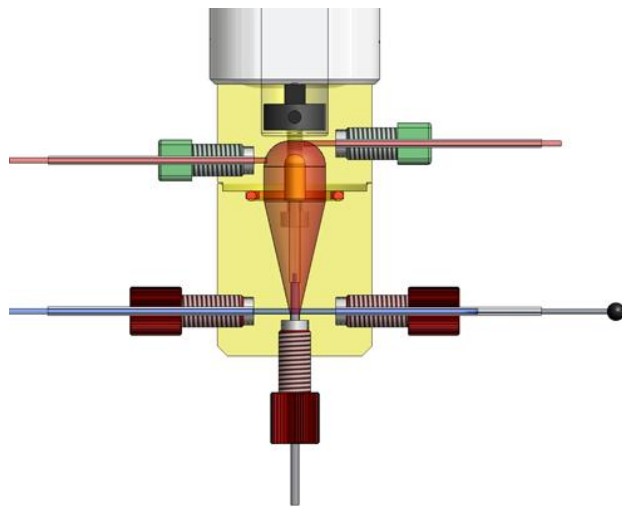

Step 3:

Dose the suspension into the stirring bottle until the stirring bottle is full and the suspension overflows at the outlet to the application. Then stop the supply of the suspension.

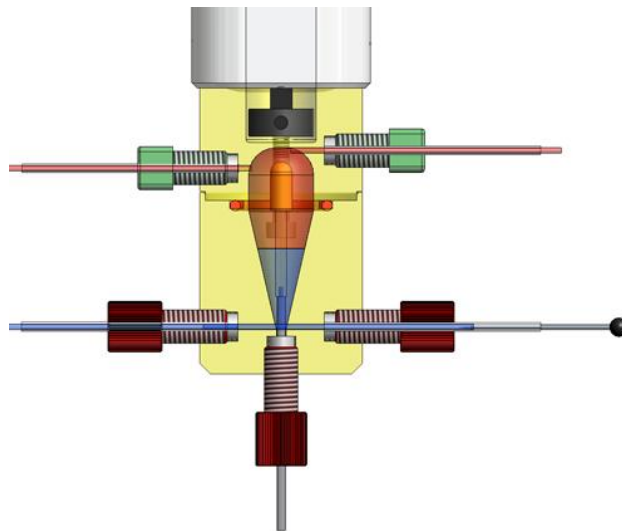

Step 4:

With the start of dosing of the carrier medium, you start the dosing of your suspension.

You are now in a position to deliver your suspension precisely into the application by dosing the carrier medium using a syringe pump.

5.3 Valves and refilling the syringe

If you have a syringe pump system with valves available, you also have the possibility of refilling the stirring bottle. For this, use the valve of the dosing unit with the carrier medium syringe. You can remove the valve and leave the plug connected.

Connect the hoses to the system as illustrated in the figure below.

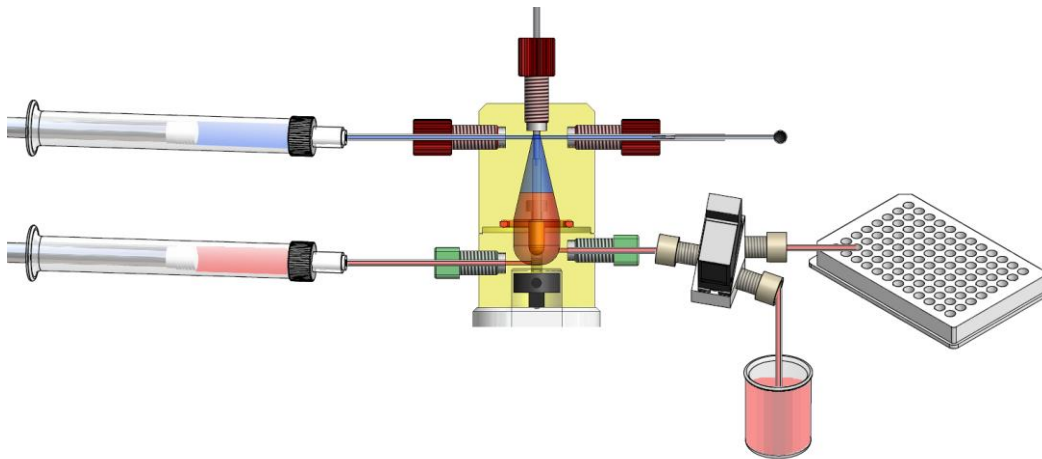

When the carrier medium is drawn into the syringe, suspension is drawn from a storage vessel into the stirring bottle. The suspension in the storage vessel should be stirred to ensure uniform mixing during filling.



IMPORTANT

You can disconnect the valves at the knurled screw and place them alongside the syringe pump. In many cases this simplifies the connection of the hoses.



ATTENTION

Risk of clogging of the valve!!

We advise against the use of the valves with coarse solid/liquid suspensions or highly viscous media as deposits and clogging may occur inside the valve or at the connection points.

6 Shutting Down

6.1 Cleaning

When the stirring bottle has been emptied after use, it can be dismantled and cleaned using alcohol, distilled water and compressed air. The body of the stirring bottle is made of Tecason® and can be autoclaved. This applies also to the hoses, fittings, ferrules and the stirring clapper. Instructions for dismantling can be found in the following section.



ATTENTION

Risk of leakage!

Dismantle or disconnect the stirring bottle only after finishing dosing and subsequent cleaning.

6.2 Dismantling of the stirring bottle

The stirring bottle must be removed for autoclaving. Please ensure that the stirring bottle is emptied as far as possible before removing. Proceed as follows to remove the stirring bottle.

1. Disconnect the side fittings and pull them off together with hose and ferrule.

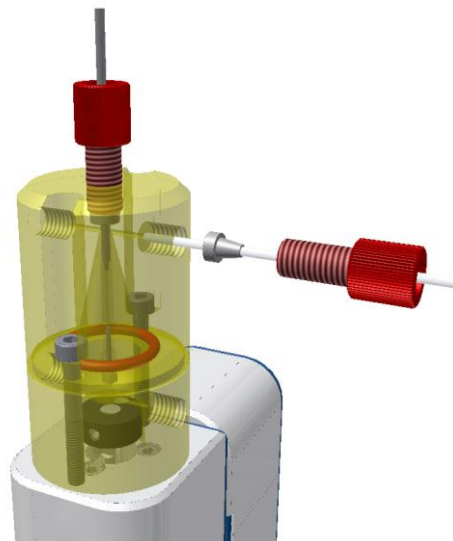

2. Loosen the fixing screws using the Allen key.

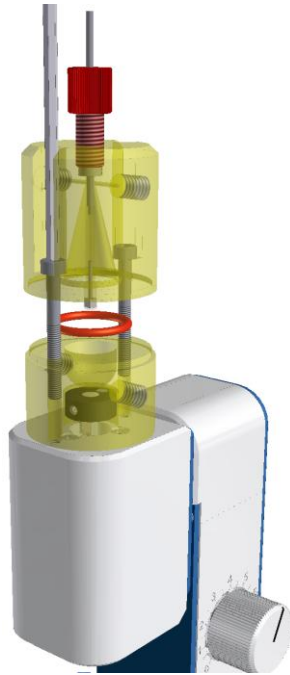

The stirring bottle halves can now be separated from one another and the seal ring removed.

3. The stirring clapper can be easily removed by loosening the upper fitting.

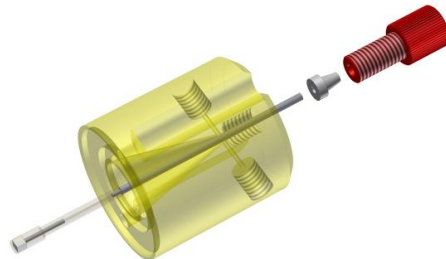

4. The dismantled stirring bottle should now consist of the following individual parts:

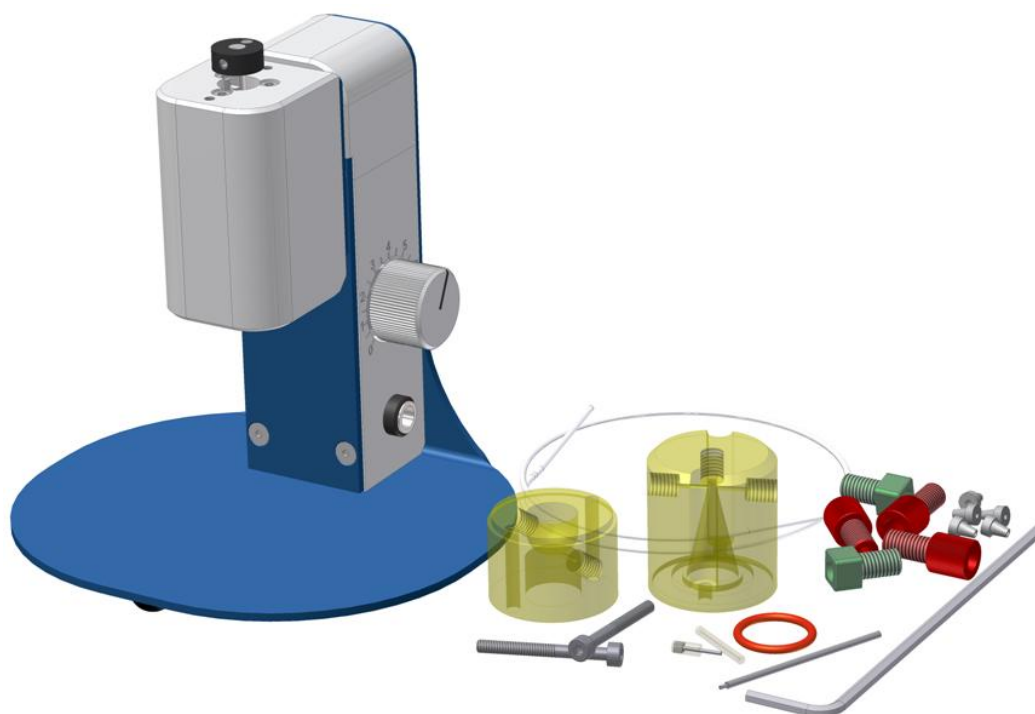

The parts coming into contact with the fluid (stirring bottle body, seal ring, fittings, ferrules, hoses and stirring clapper) can be sterilised by autoclaving, by UV radiation or by rinsing with alcohol.



IMPORTANT

Should you wish to buy replacement hoses, please ensure that the hoses have an outside diameter of 1.6 mm (1/16"). The fittings are standard HPLC fittings with a ¼" UNF-28 thread for 1.6 mm hoses (outside diameter) with matching ferrules.

6.3 Assembly of the stirring bottle

Carry out the dismantling steps in reverse order to assemble the stirring bottle.



IMPORTANT

After every application, inspect the condition of the hoses used and the connection materials for wear during disassembly and replace, if necessary.

7 Transport and Storage

7.1 Transport

Use only the original packaging for transport or shipment of the neMIX stirring bottle.

7.2 Storage

Observe also the information in the technical data sheets (chapter 4) for operation and storage of the stirring bottle.

8 Troubleshooting

This section is intended to help you resolve problems that may occur during work with the neMIX stirring bottle:

No liquid delivered

Despite the syringe being filled, no medium emerges from the outlet hose.

Procedure

Check whether liquid emerges at the hose connections of the stirring bottle. If this is the case, check the tightness of the fittings and retighten, if necessary, or replace the connection elements.

9 Maintenance and Care

Cleaning of the stirring bottle is described in section 6.1. When used for its intended purpose, the appliance is maintenance-free. Should faults nevertheless occur, please contact cetoni GmbH.