

# NEMESYS

December 2008

## OEM Tubing Pump Hardware Reference

 **cetoni**<sup>®</sup>

---

The information and data contained in this documentation can be amended without notice. No part of this documentation can be duplicated or transferred for any purpose without the express written consent of cetoni GmbH, irrespective of the nature or medium of distribution; electronic or mechanical.

The general terms and conditions of cetoni GmbH apply. Alternative agreements must be in written form.

Copyright © cetoni GmbH – Automation and micro systems. All rights reserved

WINDOWS is a registered trade mark of the Microsoft Corporation.

The Windows logo is a registered trade mark <sup>™</sup> of the Microsoft Corporation.

## **Software License**

The software and the documents provided are protected by copyright. Installation declares your acceptance of the conditions of the licensing contract.

## **License Agreement**

cetoni GmbH grants the purchaser the non-exclusive and non-transferable license to use the software on a stand alone computer or respectively a networked computer system (LAN). It is expressly forbidden to copy or duplicate the software in part or in whole in any way. The same applies to mixing and combining the software with other software. The purchaser is entitled to make one single copy of the software for security purposes (backup). cetoni GmbH retains the right to amend, further develop, improve, or through a new development; replace the software. cetoni is under no obligation to inform the purchaser of amendments, new/further developments or improvements, or to make these available. A legally binding assurance of certain features is not given. cetoni is not liable for damages unless the damages are as a result of willful intent or gross negligence on the part of cetoni GmbH or its employees. Any liability for indirect, collateral, or consequential damages is excluded.



cetoni GmbH  
Am Wiesenring 6  
D- 07554 Korbußen, Germany  
Phone: +49 (0) 36602 338-0  
Fax: +49 (0) 36602 338-11

E-mail: [info@cetoni.de](mailto:info@cetoni.de)  
Internet: [www.cetoni.de](http://www.cetoni.de)

---

# 1 Summaries and directories

## 1.1 Table of contents

<b>1 Summaries and directories .....</b>	<b>4</b>
1.1 Table of contents.....	4
1.2 Change history .....	7
<b>2 Basic Information .....</b>	<b>8</b>
2.1 Foreword .....	8
2.2 Application purpose.....	8
<b>3 Safety Instructions .....</b>	<b>9</b>
3.1 Signs and Key Words Used .....	9
3.2 Safety precautions .....	9
3.2.1 Measures for safe operation .....	11
3.2.2 Safety devices on the unit.....	11
3.2.3 Condition of the unit .....	11
3.3 Warranty and Liability.....	12
<b>4 Performance Data.....</b>	<b>13</b>
4.1 Electrical data.....	13
4.2 Inputs.....	13
4.3 Outputs.....	13
4.4 Interfaces.....	13
4.5 Ambient temperature- / Humidity range .....	13
4.6 Mechanical Data .....	14
4.7 Performance.....	14
4.8 Tubing .....	14
4.9 Connections .....	14
<b>5 Connections.....</b>	<b>15</b>
5.1 Overview .....	15
5.2 Power supply.....	16
5.2.1 Power supply connector (J1) .....	16
5.3 CAN connector (J2, J3).....	17
5.4 Signal connector (J4).....	18
5.4.1 Digital input 1 “General Purpose” (J4/8) .....	19
5.4.2 Digital input 2 “General Purpose” (J4/7) .....	20

5.4.3	Digital input 3 “General Purpose” (J4/6).....	21
5.4.4	Digital input 4 “General Purpose” (J4/5).....	22
5.4.5	Auxiliary output voltage (J4/9).....	22
5.4.6	Digital output 3 “General Purpose” (J4/11) .....	23
5.4.7	Digital output 4 “General Purpose” (J4/10) .....	24
5.4.8	Analogue input 1 “General Purpose” (J4/16) .....	26
5.4.9	Analogue input 2 “General Purpose” (J4/15) .....	27
5.5	RS-232 connector (J5) .....	28
<b>6</b>	<b>Cable Set.....</b>	<b>29</b>
6.1	Power cable (Connector J1).....	29
6.1.1	Description.....	29
6.1.2	Cable head A pin assignment .....	30
6.1.3	Cable head B pin assignment .....	30
6.2	Power interconnect cable (Connector J1) .....	31
6.2.1	Description.....	31
6.2.2	Cable head A and B pin assignment.....	32
6.3	CAN cable (Connector J2/J3).....	33
6.3.1	Description.....	33
6.3.2	Cable head A pin assignment .....	34
6.3.3	Cable head B pin assignment .....	34
6.4	CAN interconnect cable (Connector J2/J3).....	35
6.4.1	Description.....	35
6.4.2	Cable head A and B pin assignment.....	36
6.5	CAN termination plug (Connector J2/J3).....	37
6.6	RS232-COM cable (Connector J5).....	38
6.6.1	Description.....	38
6.6.2	Cable head A pin assignment .....	39
6.6.3	Cable head B pin assignment .....	40
6.7	neMESYS OEM USB-to-CAN interface .....	41
6.7.1	Description.....	41
6.7.2	Cable head A pin Assignment .....	42
<b>7</b>	<b>Installation and configuration.....</b>	<b>43</b>
7.1	External wiring via CAN interface .....	43
7.1.1	Drawing .....	43
7.1.2	Description.....	44
7.2	External wiring via RS-232 interface .....	46
7.2.1	Drawing .....	46
7.2.2	Description.....	47
7.3	CAN Bus Termination.....	48

---

<b>8 Tube fitting</b> .....	<b>49</b>
8.1 Removing pump-head cover .....	49
8.2 Removing cassette from pump head .....	50
8.3 Inserting the tube .....	50
8.4 Mounting the pump-head cover .....	52
<b>9 Dimension drawing</b> .....	<b>53</b>

---

## 1.2 Change history

Ver	Date	Change
1.00	09.12.2008	<ul style="list-style-type: none"><li>• First version of neMESYS OEM Tubing Pump hardware reference</li></ul>

---

## 2 Basic Information

### 2.1 Foreword

Thank you for deciding to purchase a cetoni product. We would like to support you with this manual as far as possible in your interaction with the neMESYS OEM tubing pump. We are directly available for any questions or suggestions that you may have.

You should not use the neMESYS tubing pump before you have carefully read and understood this manual. We wish you much success in your work with the neMESYS OEM tubing pumps.

This documentation “Hardware Reference” provides the hardware details of the neMESYS OEM tubing pump. It contains performance data, connections, specification, pin assignment and wiring examples.

The latest edition of these “Hardware Reference”, additional documentation and software for the neMESYS OEM tubing pumps are available on the internet at <http://www.cetoni.de> category *Service* → *Downloads*.

### 2.2 Application purpose

The neMESYS OEM tubing pump serves for precise and reliable dosage of fluids.

---

## 3 Safety Instructions

### 3.1 Signs and Key Words Used

The following symbols are used in this handbook and are designed to aid your navigation through this document:



#### **IMPORTANT**

*Indicates tips for users and other especially useful information on how to act in dangerous or harmful situations.*



#### **NOTICE**

*Indicates a potentially harmful situation. Failure to avert this situation may result in damage to the product or anything nearby.*



#### **CAUTION**

*Indicates a potentially dangerous situation. Failure to avert this situation may result in light or minor injuries and property damage.*

### 3.2 Safety precautions

The safety of the user and a failure-free operation of the unit are only assured if original parts are used. Warranty claims will not be accepted for damage due to the utilisation of alien accessories or expendables.



#### **IMPORTANT**

*The pump must not be used as a medical device or for medical purposes and in explosion proof chambers or in the presence of flammable gases or fumes.*

The unit has been developed and constructed in such a way as to largely exclude hazards due to its intended use. Nevertheless, you should observe the following security measures in order to exclude any remaining hazards.



### **Skilled Personnel**

*Installation and starting of the equipment shall only be performed by experienced, skilled personnel.*



### **Operational Reliability**

*Before operating the unit, the user must at all times ensure the operational reliability and the adequate and orderly condition of the unit.*



### **Statutory Regulations**

*The user must ensure that the dosing module and the components belonging to it are assembled and connected according to local statutory regulations.*



### **Additional Safety Equipment**

*An electronic apparatus is not fail-safe in principle. Machines and apparatus must therefore be fitted with independent monitoring and safety equipment. If the equipment breaks down, if it is operated incorrectly, if the control unit breaks down or if the cables break, etc., it must be ensured that the drive or the complete apparatus is kept in a safe operating mode.*



### **Repairs**

*Repairs may be made by authorized personnel only or by the manufacturer. It is dangerous for the user to open the unit or make repairs to it.*



### **Danger**

*Do ensure that during the installation of the neMESYS OEM tubing pump no apparatus is connected to the electrical supply. After switching on, do not touch any live parts!*



### **Max. Supply Voltage**

*Make sure that the supply voltage is between 9 and 24 VDC. Voltages higher than 27 VDC or of wrong polarity will destroy the unit.*



### **Electrostatic Sensitive Device (ESD)**

**CAUTION**

*Risk of injury from damaged cables and plug devices.  
Inspect the unit and lines for damage before starting the unit! Never operate the unit with damaged lines and plugging devices!*

**CAUTION**

*Risk of crushing by touching moving parts!  
Moving parts must not be touched whilst the unit is in operation*

**CAUTION**

*Risk of damaging pump parts!  
Do not operate the pump before the cassettes are fully snapped-in.*

## 3.2.1 Measures for safe operation

### Electromagnetic emissions

The neMESYS dosing system is intended for use in any type of facility, including living quarters, and those that are connected to a public mains network that supplies buildings used for living purposes.

### Electric disturbances

The quality of the supply voltage should be to the standard of a typical business or hospital environment.

### Magnetic disturbances

Do not place power connector cables and other appliances in close proximity of the unit and its cables. Portable and mobile communication devices should not be used in closer proximity of the unit or its cables than the recommended safety distance!

## 3.2.2 Safety devices on the unit

The unit can be switched off at any time in an emergency by disabling power supply. This will cause no damage to the unit.

## 3.2.3 Condition of the unit

Irrespective of the faultless manufacture of the unit, damage can occur whilst the unit is in operation. With this in mind, always carry out a visual check of the components mentioned before use. Pay particular attention to crushed cables, damaged tubing, and deformed plugs. If you should notice any damage, please do not use the unit and inform

---

cetoni GmbH without delay. cetoni will return the unit to an operational condition as quickly as possible. Do not attempt to carry out a repair to the unit.

### **3.3 Warranty and Liability**

The present unit left our company in perfect condition. The manufacturer is the only entity permitted to open the unit. If the unit is opened by an unauthorised person, all guarantee and liability entitlements, particularly damage entitlements due to personal injuries, are extinguished

The duration of the warranty is 1 year from the day of delivery. It is not extended or renewed due to work carried out under warranty.

cetoni GmbH only considers itself responsible for the unit with regard to safety, reliability and function; if assembly, new-settings, changes, extensions and repairs are carried by cetoni GmbH or an authorised centre, and if the unit has been used in accordance with the instruction manual.

The dosing unit system underlies safety regulation standards. Industrial property rights are reserved on the circuits, methods, names, software programs, and units.

## 4 Performance Data

### 4.1 Electrical data

Supply voltage VCC (Ripple < 10%).....	9 – 24 VDC
Max. output current $I_{max}$ (<1sec).....	1.94 A
Continuous output current $I_{cont}$ .....	0.7 A
Dosing Unit Current peak at 24 VDC.....	1.4 A
Dosing Unit Current typical at 24 VDC.....	0.7 A

### 4.2 Inputs

Digital input 1 (“General Purpose”).....	+2.4 ... +24 VDC (Ri = 11 k $\Omega$ )
Digital input 2 (“General Purpose”).....	+2.4 ... +24 VDC (Ri = 11 k $\Omega$ )
Digital input 3 (“General Purpose”).....	+2.4 ... +24 VDC (Ri = 11 k $\Omega$ )
Digital input 4 (“General Purpose”).....	+2.4 ... +24 VDC (Ri = 11 k $\Omega$ )
Digital input 5 (“Reserved – do not use”).....	+2.4 ... +24 VDC (Ri = 11 k $\Omega$ )
Digital input 6 (“Reserved – do not use”).....	+2.4 ... +24 VDC (Ri = 11 k $\Omega$ )
Analogue input 1.....	Resolution 10-bit 0 ... +5 V (Ri = 36 k $\Omega$ )
Analogue input 2.....	Resolution 10-bit 0 ... +5 V (Ri = 36 k $\Omega$ )

### 4.3 Outputs

Digital output 3 (“General Purpose”).....	open drain max. 24 VDC (IL < 50 mA)
Digital output 4 (“General Purpose”).....	open drain max. 24 VDC (IL < 50 mA)

### 4.4 Interfaces

RS-232.....	RxD; TxD max. 115 200 bit/s
CAN.....	CAN_H (high); CAN_L (low) max.1 Mbit/s

### 4.5 Ambient temperature- / Humidity range

Operating.....	-10 ... +45°C
Storage.....	-40 ... +85°C
Humidity.....	non condensing 20 ... 80 %

## 4.6 Mechanical Data

Weight .....approx. 1330 g  
Dimensions (L x W x H)..... 209 x 110 x 96.2 mm  
Mounting plate ..... for M3 screws

## 4.7 Performance

Rotation speed .....0.1 – 60 rpm  
Flow rate ..... 0.00013 – 15.7 ml/min  
Channels ..... 1 – 6  
Pump rollers .....5

## 4.8 Tubing

Tubing type ..... 2-stop collared tubing  
Inner diameter .....0.13 – 2.79 mm  
Cassettes .....POM-C (blue)

## 4.9 Connections

Supply      On board (J1): ..... dual row male header (2 poles) Molex Mini-Fit Jr.<sup>TM</sup>  
                 Suitable plug: ..... dual row female receptacle (2 poles) Molex Mini-Fit Jr.<sup>TM</sup> 39-01-2020  
                 Suitable terminal: ..... female crimp terminal Molex Mini-Fit Jr.<sup>TM</sup> 444-76-1111 (AWG 18-24)

CAN            On board (J2, J3): .. dual row male header (4 poles) Molex Micro-Fit 3.0<sup>TM</sup>  
                 Suitable plug: ..... Dual row female receptacle (4 poles) Molex Micro-Fit 3.0<sup>TM</sup> 430-25-0400  
                 Suitable terminal: ..... female crimp terminal Molex Micro-Fit 3.0<sup>TM</sup> 430-30-0010(AWG26-30)

Signal        On board (J4): ..... dual row male header (16 poles) Molex Micro-Fit 3.0<sup>TM</sup>  
                 Suitable plug: ..... dual row female receptacle (16 poles) Molex Micro-Fit 3.0<sup>TM</sup> 430-25-1600  
                 Suitable terminal: ..... female crimp terminal Molex Micro-Fit 3.0<sup>TM</sup> 430-30-0010(AWG26-30)

RS232        On board (J5): ..... dual row male header (6 poles) Molex Micro-Fit 3.0<sup>TM</sup>  
                 Suitable plug: ..... dual row female receptacle (6 poles) Molex Micro-Fit 3.0<sup>TM</sup> 430-25-0600  
                 Suitable terminal: ..... female crimp terminal Molex Micro-Fit 3.0<sup>TM</sup> 430-30-0010(AWG26-30)

# 5 Connections

## 5.1 Overview

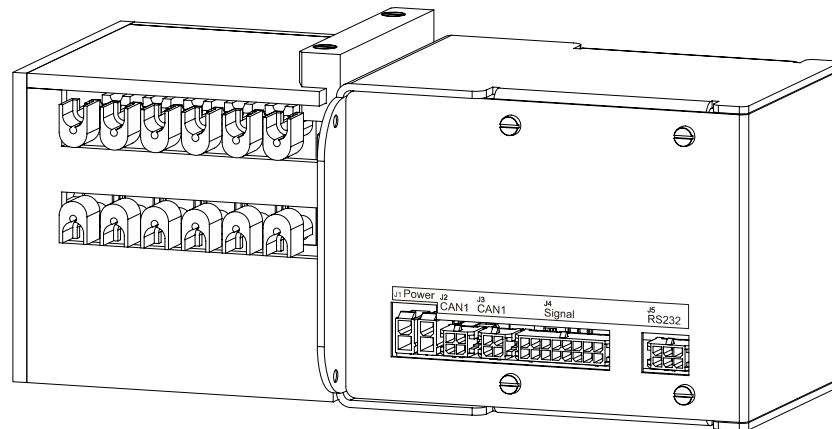

Figure 1 - neMESYS OEM tubing pump connector description

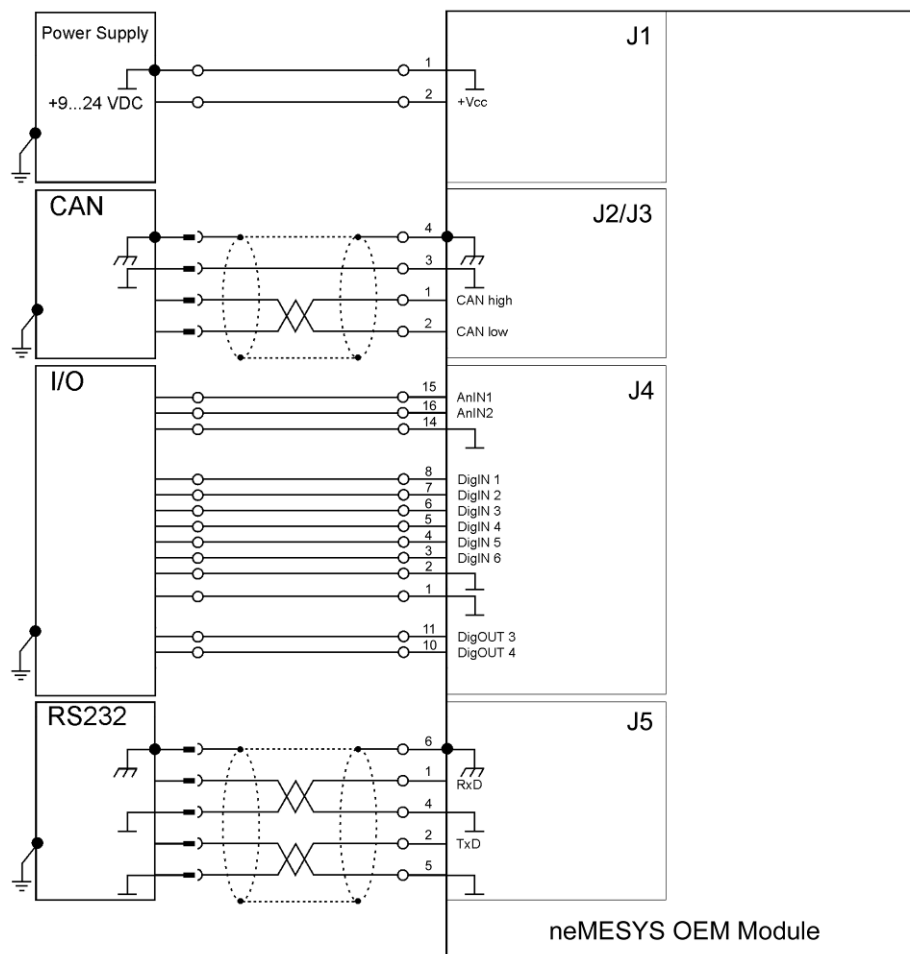

Figure 2 - Wiring diagram (overview)

## 5.2 Power supply

### 5.2.1 Power supply connector (J1)

Any available power supply can be used, provided it meets the minimal requirements set out below.

#### Power supply requirements

Output voltage	VCC min. 9 VDC; VCC max. 24 VDC
Ripple	< 10 %
Output current	Depending on load and on number of modules continuous typical of 1 module: 0.7 A acceleration, short-time max. of one module 1.94 A

#### Connector

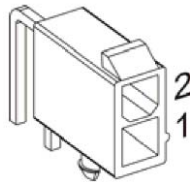

Figure 3 - Power connector (J1)

Pin No.	Signal	Description
1	Power_Gnd	Ground of supply voltage
2	+V <sub>CC</sub>	Supply voltage +9...+24 VDC

#### Notes

Suitable connector:	Molex Mini-Fit Jr.™ 2 poles (39-01-2020)
Suitable crimp terminals:	Molex Mini-Fit Jr.™ female crimp terminals (444-76-1111)
Suitable hand crimper:	Molex hand crimper (69008-0724)

## 5.3 CAN connector (J2, J3)

Standard type	CAN high-speed ISO 11898 compatible
Maximum bit rate	1 Mbit/s
Max. number of CAN nodes	127
Protocol	CANopen DS-301 V4.02 CANopen DSP-402
Identifier setting	by DIP-Switch or software

Connection neMESYS – CAN bus line CiA DS-102

neMESYS OEM	CAN 9 pin D-Sub (DIN41652)
Connector J1 (J2) pin 1 “CAN high”	Pin 7 “CAN_H” high bus line
Connector J1 (J2) pin 2 “CAN low”	Pin 2 “CAN_L” low bus line
Connector J1 (J2) pin 3 “CAN GND”	Pin 3 “CAN_GND” Ground
Connector J1 (J2) pin 4 “CAN shield”	Pin 5 “CAN_Shield” Cable Shield

### Note:

- Please consider your CAN Master port maximal baud rate.
- The standard baud rate setting (factory setting) is 1 Mbit/s

### Connector

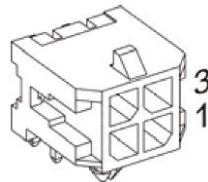

Figure 4 - CAN connector (J2, J3)

Pin No.	Signal	Description
1	CAN high	CAN high bus line
2	CAN low	CAN low bus line
3	CAN GND	CAN Ground
4	CAN shield	Cable shield

Suitable connector: Molex Micro-Fit 3.0™ 4 poles (430-25-0400)

Suitable crimp terminals: Molex Micro-Fit 3.0™ female crimp terminals (430-30-0010)

Suitable hand crimper: Molex hand crimper (69008-0983)

## 5.4 Signal connector (J4)

“General Purpose” digital I/O’s and analogue inputs are provided.

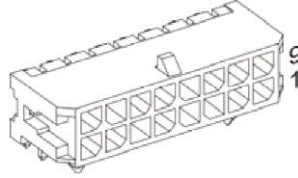

Figure 5 - Signal connector (J4)

Pin No.	Signal	Description
1	D_Gnd	Digital signal ground
2	D_Gnd	Digital signal ground
3	DigIN 6	Digital input 6 – Reserved – do not use
4	DigIN 5	Digital input 5 – Reserved – do not use
5	DigIN 4	Digital input 4 “General Purpose”
6	DigIN 3	Digital input 3 “General Purpose”
7	DigIN 2	Digital input 2 “General Purpose”
8	DigIN 1	Digital input 1 “General Purpose”
9	+Vout	Auxiliary supply output voltage (+5 VDC / 10 mA)
10	DigOUT 4	Digital output 4 “General Purpose”
11	DigOUT 3	Digital output 3 “General Purpose”
12	+Vcc (9...24)	Power supply voltage (+9...24 VDC)
13	Power_Gnd	Power Ground
14	A_Gnd	Analogue signal ground
15	AnIN 2	Analogue Input 2 “General Purpose”
16	AnIN 1	Analogue Input 1 “General Purpose”

## 5.4.1 Digital input 1 “General Purpose” (J4/8)

“General Purpose” input by default and can be configured via software setting.

Connector No. and Pin No.	Connector (J4) Pin number [8]
Input voltage	0 ... 24VDC
Max. input voltage	-30 ... +30 VDC
Logic 0	< 0.7 VDC
Logic 1	> 2.4 VDC
Input resistance	typical 22 k $\Omega$ (< 3.3 V) typical 11 k $\Omega$ (> 3.3 V)
Input current at logic 1	typical 2 mA @ 24 VDC
Switching delay	< 300 $\mu$ s @ 5 VDC

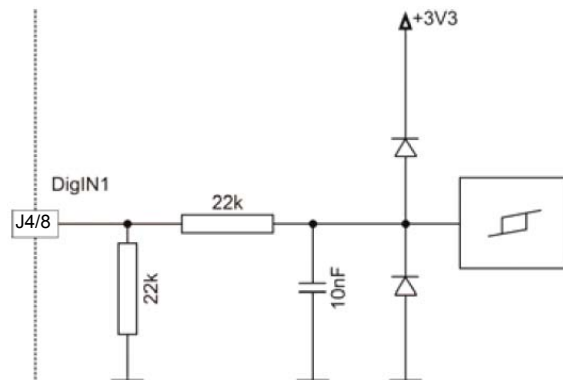

Figure 6 - Digital input 1

## 5.4.2 Digital input 2 “General Purpose” (J4/7)

“General Purpose” input by default and can be configured via software setting.

Connector No. and Pin No.	Connector (J4) Pin number [7]
Input voltage	0 ... 24VDC
Max. input voltage	-30 ... +30 VDC
Logic 0	< 0.7 VDC
Logic 1	> 2.4 VDC
Input resistance	typical 22 k $\Omega$ (< 3.3 V) typical 11 k $\Omega$ (> 3.3 V)
Input current at logic 1	typical 2 mA @ 24 VDC
Switching delay	< 1 $\mu$ s @ 5 VDC

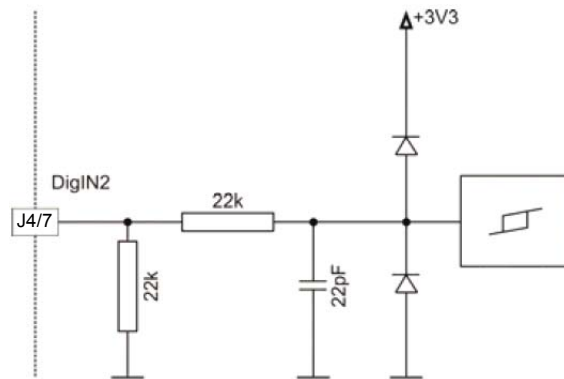

Figure 7 - Digital input 2

### 5.4.3 Digital input 3 “General Purpose” (J4/6)

“General Purpose” input by default and can be configured via software setting.

Connector No. and Pin No.	Connector (J4) Pin number [6]
Input voltage	0 ... 24VDC
Max. input voltage	-30 ... +30 VDC
Logic 0	< 0.7 VDC
Logic 1	> 2.4 VDC
Input resistance	typical 22 k $\Omega$ (< 3.3 V) typical 11 k $\Omega$ (> 3.3 V)
Input current at logic 1	typical 2 mA @ 24 VDC
Switching delay	< 1 $\mu$ s @ 5 VDC

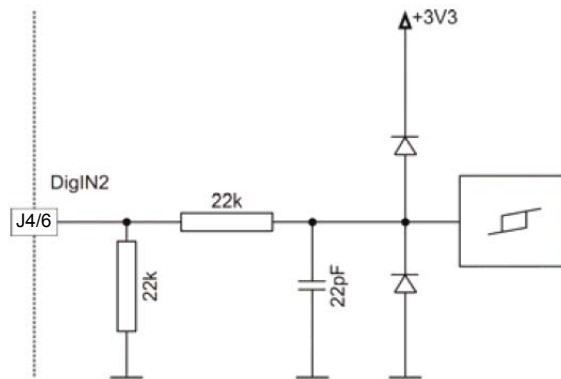

Figure 8 - Digital input 3

## 5.4.4 Digital input 4 “General Purpose” (J4/5)

“General Purpose” input by default and can be configured via software setting.

Connector No. and Pin No.	Connector (J4) Pin number [5]
Input voltage	0 ... 24VDC
Max. input voltage	-30 ... +30 VDC
Logic 0	< 0.7 VDC
Logic 1	> 2.4 VDC
Input resistance	typical 22 k $\Omega$ (< 3.3 V) typical 11 k $\Omega$ (> 3.3 V)
Input current at logic 1	typical 2 mA @ 24 VDC
Switching delay	< 300 $\mu$ s @ 5 VDC

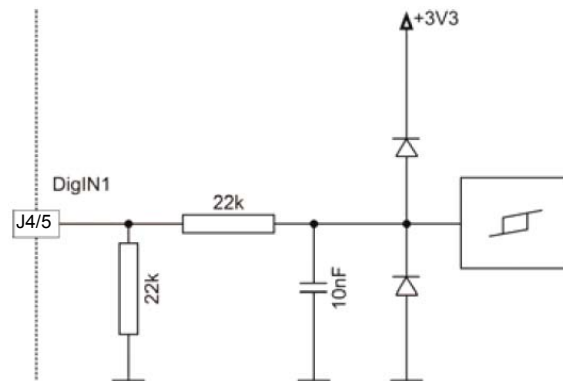

Figure 9 - Digital input 4

## 5.4.5 Auxiliary output voltage (J4/9)

Auxiliary output voltage can be used as power supply for external devices (switches...) connected to neMESYS OEM digital inputs. The auxiliary output voltage is short circuit protected.

Connector No. and Pin No.	Connector (J4) Pin number [9]
Output voltage	+5 VDC
Max. output current	10 mA

## 5.4.6 Digital output 3 “General Purpose” (J4/11)

“General Purpose” output by default and can be configured via software setting.

Connector No. and Pin No.	Connector (J4) Pin number [11]
Circuit	Open Collector (internal pull-up resistor 2k2 and diode to +5 VDC)

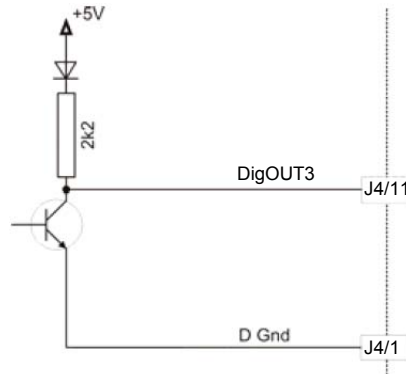

Figure 10 - Digital output 3 circuit

### Wiring examples:

#### a) DigOut3 “sink”

Max. input voltage	+30 VDC
Max. load current	50 mA
Max. voltage drop	< 1.0V @ 50 mA

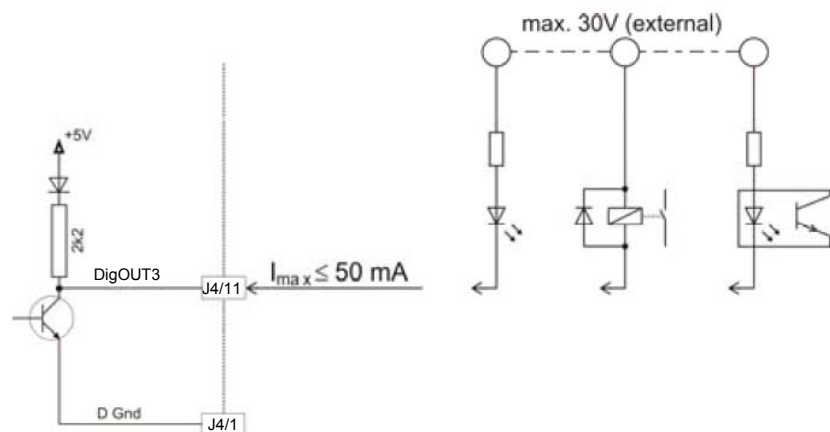

Figure 11 - Digital output 3 external wiring example a)

b) DigOut3 “source”

Output voltage	$U_{out} \approx 5V - 0.75V - (I_{load} \times 2200\Omega)$
Max. load current	$I_{load} \leq 2mA$

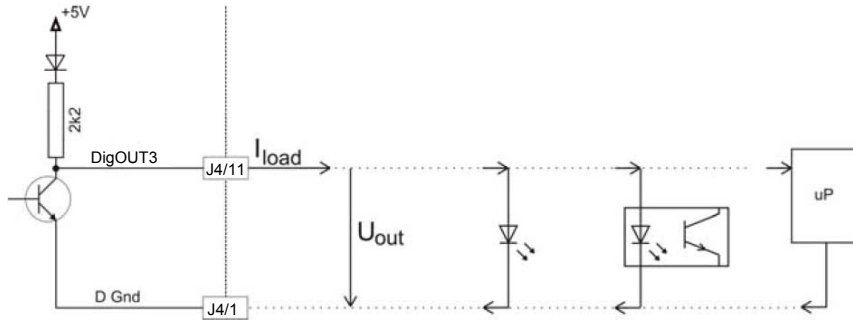

Figure 12 - Digital output 3 external wiring example b)

### 5.4.7 Digital output 4 “General Purpose” (J4/10)

“General Purpose” output by default and can be configured via software setting.

Connector No. and Pin No.	Connector (J4) Pin number [10]
Circuit	Open Collector (internal pull-up resistor 2k2 and diode to +5 VDC)

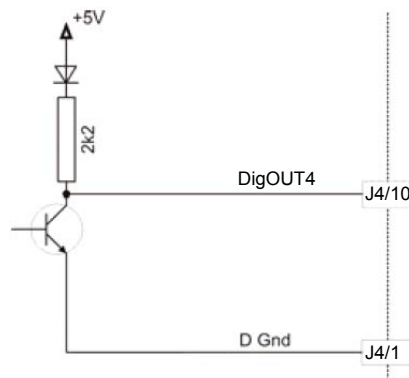

Figure 13 - Digital output 4 circuit

**Wiring examples:**

a) DigOut4 “sink”

Max. input voltage	+30 VDC
Max. load current	50 mA
Max. voltage drop	< 1.0V @ 50 mA

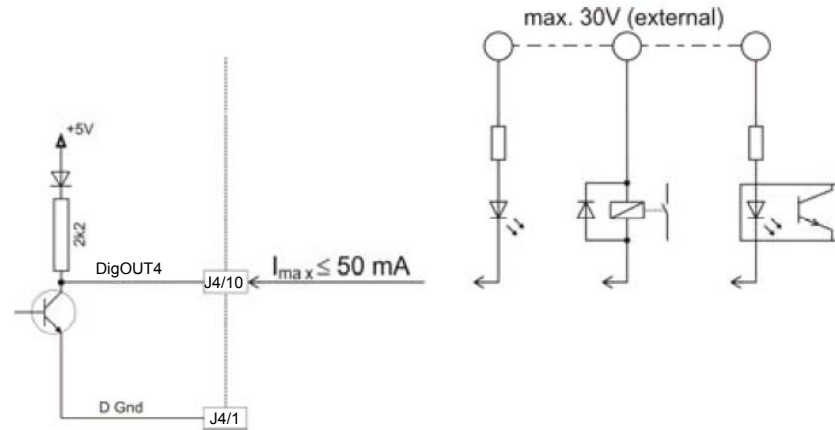

Figure 14 - Digital output 4 external wiring example a)

b) DigOut4 “source”

Output voltage	$U_{out} \approx 5V - 0.75V - (I_{load} \times 2200\Omega)$
Max. load current	$I_{load} \leq 2\text{mA}$

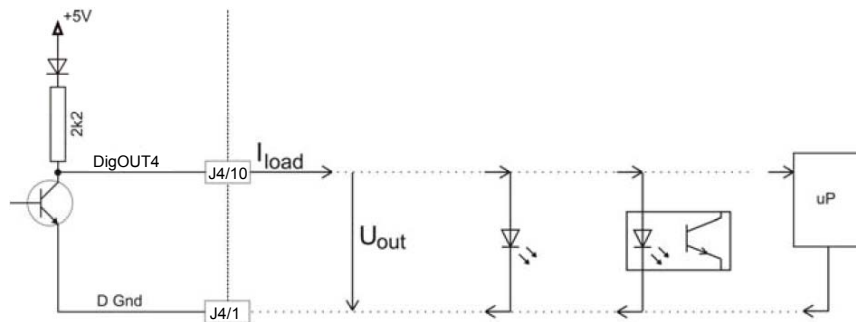

Figure 15 - Digital output 4 external wiring example b)

## 5.4.8 Analogue input 1 “General Purpose” (J4/16)

“General Purpose” analogue input by default and can be configured via software setting.

Connector No. and Pin No.	Connector (J4) Pin number [16]
Input voltage range	0 ... 5 VDC
Max. input voltage	-30 ... +30 VDC
Input resistance	typical 36 k $\Omega$ against A_Gnd [14]
A/D converter	10-bit
Resolution	0.005V

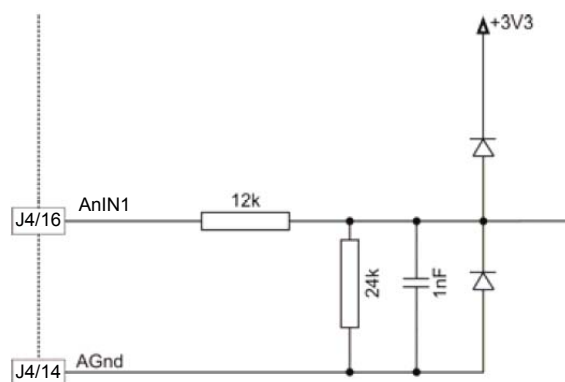

Figure 16 - Analogue input 1

## 5.4.9 Analogue input 2 “General Purpose” (J4/15)

“General Purpose” analogue input by default and can be configured via software setting.

Connector No. and Pin No.	Connector (J4) Pin number [15]
Input voltage range	0 ... 5 VDC
Max. input voltage	-30 ... +30 VDC
Input resistance	typical 36 k $\Omega$ against A_Gnd [14]
A/D converter	10-bit
Resolution	0.005V

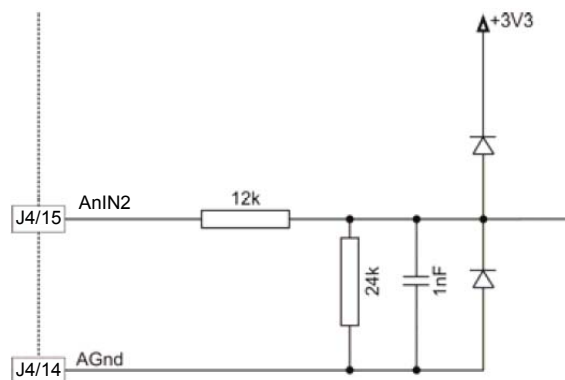

Figure 17 - Analogue input 2

## 5.5 RS-232 connector (J5)

Maximum input voltage	± 30 V
Output voltage	typical ± 9 V @ 3k to Ground
Maximum bit rate	115 200 bit/s
Internal RS232 driver/receiver	EIA RS232 standard

### Connection neMESYS OEM tubing pump – PC

neMESYS OEM	PC
Connector J3 pin 4+5 GND	Pin 5 GND
Connector J3 pin 1 “neMESYS RxD”	Pin 3 “PC TxD”
Connector J3 pin 2 “neMESYS TxD”	Pin 2 “PC RxD”

#### Note:

- Please consider your PC’s / Microcontroller’s serial port maximum baud rate
- The standard baud rate setting (factory setting) is 115200 bauds.

#### Connector

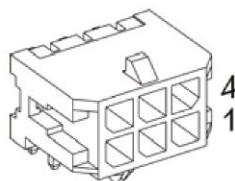

Figure 18 - RS-232 connector (J5)

Pin No.	Signal	Description
1	neMESYS RxD	neMESYS RS232 receive
2	neMESYS TxD	neMESYS RS232 transmit
3	NC	Not connected
4	GND	RS232 Ground
5	GND	RS232 Ground
6	Shield	Cable shield

Suitable connector: Molex Micro-Fit 3.0™ 6 poles (430-25-0600)

Suitable crimp terminals: Molex Micro-Fit 3.0™ female crimp terminals (430-30-0010)

Suitable hand crimper: Molex hand crimper (69008-0983)

## 6 Cable Set



### 6.1 Power cable (Connector J1)

#### 6.1.1 Description



Figure 19 - Power cable

The power cable is a 2 x 0.75 mm<sup>2</sup>, 1.5 m length cable.

Cable head A	Cable head B
 <p data-bbox="338 1668 831 1792">The used Molex Mini-Fit Jr.™ connector fits to neMESYS OEM tubing pump connector J1 Power Supply</p>	 <p data-bbox="879 1668 1316 1792">Connect this cable end to the power supply (+9 ... +24 VDC) - Cable end sleeve: 0.75 mm<sup>2</sup></p>

## 6.1.2 Cable head A pin assignment

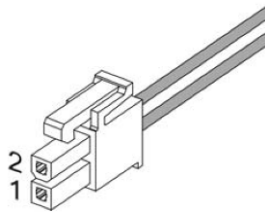

Figure 20 - Pin assignment power cable head A

Pin No.	Color	Signal	Description
1	Black	Power_Gnd	Ground of supply voltage
2	Brown	+V <sub>CC</sub>	Supply voltage +9...+24 VDC

Connector: Molex Mini-Fit Jr.™ 2 poles (39-01-2020)

Crimp terminals: Molex Mini-Fit Jr.™ female crimp terminals (444-76-1112)

Hand crimper: Molex hand crimper (Europe: 69008-0724; America: 11-01-0197)

## 6.1.3 Cable head B pin assignment

Pin No.	Color	Signal	Description
1	Black	Power_Gnd	Ground of supply voltage
2	Brown	+V <sub>CC</sub>	Supply voltage +9...+24 VDC



## 6.2 Power interconnect cable (Connector J1)

### 6.2.1 Description



Figure 21 - Power interconnect cable

The power interconnect cable is a 2 x 0.75 mm<sup>2</sup>, 0.2 m length cable.

Cable head A	Cable head B
 <p>The used Molex Mini-Fit Jr.™ connector fits to neMESYS OEM tubing pump connector J1 Power Supply</p>	 <p>Connect this cable end to J1 of next neMESYS OEM tubing pump to route power from previous pump (cable head A) to this pump</p>

## 6.2.2 Cable head A and B pin assignment

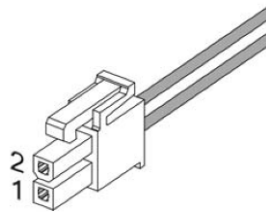

Figure 22 - Pin assignment power interconnect cable head A and B

Pin No.	Color	Signal	Description
1	Black	Power_Gnd	Ground of supply voltage
2	Brown	+V <sub>CC</sub>	Supply voltage +9...+24 VDC

Connector: Molex Mini-Fit Jr.™ 2 poles (39-01-2020)

Crimp terminals: Molex Mini-Fit Jr.™ female crimp terminals (444-76-1112)

Hand crimper: Molex hand crimper (Europe: 69008-0724; America: 11-01-0197)



## 6.3 CAN cable (Connector J2/J3)

### 6.3.1 Description



Figure 23 - CAN cable

The CAN cable is a 2 x 2 x 0.14mm<sup>2</sup>, twisted pair, shielded, 0.5 m length cable.

Cable head A	Cable head B
 <p data-bbox="336 1509 847 1585">The used Molex Micro-Fit 3.0.™ connector fits to neMESYS OEM connector J2 CAN</p>	 <p data-bbox="879 1509 1334 1630">Connect this cable end to your CAN Master or the neMESYS USB-to-CAN compact interface</p>

## 6.3.2 Cable head A pin assignment

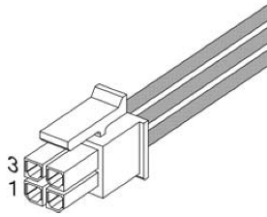

Figure 24 - Pin assignment CAN cable head A

Pin No.	Color	Signal	Description
1	Yellow	CAN high	CAN high bus line
2	Green	CAN low	CAN low bus line
3	Brown	CAN GND	CAN Ground
4	Black	CAN shield	Cable shield

Connector: Molex Micro-Fit 3.0™ 4 poles (430-25-0400)

Crimp terminals: Molex Micro-Fit 3.0™ female crimp terminals (430-30-0010)

Hand crimper: Molex hand crimper (Europe: 69008-0983; America: 63811-2800)

## 6.3.3 Cable head B pin assignment

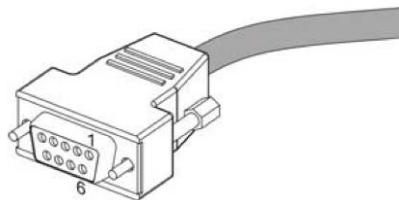

Figure 25 - Pin assignment CAN cable head B

Pin No.	Color	Signal	Description
1	Not connected		
2	Green	CAN low	CAN low bus line + 120 Ω bus termination
3	Brown	CAN GND	CAN Ground
4	Not connected		
5	Shield	CAN shield	Cable shield
6	Not connected		
7	Yellow	CAN high	CAN high bus line + 120 Ω bus termination
8	Not connected		
9	Not connected		

Connector: Female D-Sub connector DIN 41652, 9 poles, with mounting screws

Pin assignment according to CiA DS102-2

CAN bus termination resistor of 120 Ω between pin 2 and 7



## 6.4 CAN interconnect cable (Connector J2/J3)

### 6.4.1 Description



Figure 26 - CAN interconnect cable

The CAN interconnect cable is a 2 x 2 x 0.14mm<sup>2</sup>, twisted pair, shielded, 0.2 m length cable.

Cable head A	Cable head B
 <p>The used Molex Micro-Fit 3.0.™ connector fits to neMESYS OEM CAN connectors. Connect this cable end to CAN connector J3 of the neMESYS device.</p>	 <p>Connect this cable end to the CAN connector J2 of the next neMESYS OEM tubing pump to route the CAN bus from previous pump (cable head A) to this module.</p>

## 6.4.2 Cable head A and B pin assignment

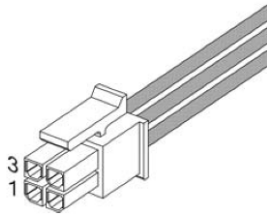

Figure 27 - Pin assignment CAN interconnect cable head A and B

Pin No.	Color	Signal	Description
1	Yellow	CAN high	CAN high bus line
2	Green	CAN low	CAN low bus line
3	Brown	CAN GND	CAN Ground
4	Black	CAN shield	Cable shield

Connector: Molex Micro-Fit 3.0.™ 4 poles (430-25-0400)

Crimp terminals: Molex Micro-Fit 3.0™ female crimp terminals (430-30-0010)

Hand crimper: Molex hand crimper (Europe: 69008-0983; America: 63811-2800)

## 6.5 CAN termination plug (Connector J2/J3)



Figure 28 - CAN termination plug

The used Molex Micro-Fit 3.0.™ connector fits to neMESYS OEM connector J2 CAN and J3 CAN.

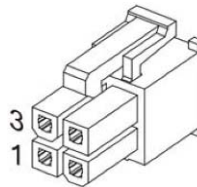

Figure 29 - Pin assignment CAN termination plug

Pin No.	Color	Signal	Description
1		Resistor terminal 1	120 Ω bus termination
2		Resistor terminal 2	120 Ω bus termination
3	Not connected		
4	Not connected		

Connector: Molex Micro-Fit 3.0.™ 4 poles (430-25-0400)

Crimp terminals: Molex Micro-Fit 3.0.™ female crimp terminals (430-30-0010)

Hand crimper: Molex hand crimper (Europe: 69008-0983; America: 63811-2800)



## 6.6 RS232-COM cable (Connector J5)

### 6.6.1 Description



Figure 30 – RS232-COM cable

The used Molex Micro-Fit 3.0.™ connector fits to neMESYS OEM connector J5 RS232.

Cable head A	Cable head B
 <p data-bbox="188 1563 694 1682">The used Molex Micro-Fit 3.0.™ connector fits to neMESYS OEM connector J5 RS232</p>	 <p data-bbox="730 1563 1225 1637">Connect this cable end to your Microcontroller/PC RS232 COM interface</p>

## 6.6.2 Cable head A pin assignment

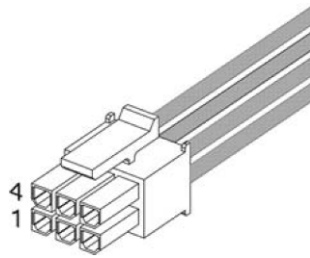

Figure 31 - Pin assignment RS232-COM cable

Pin No.	Color	Twisted wire	Signal	Description
1	Yellow	Pair 1	neMESYS RxD	neMESYS RS232 receive
2	White	Pair 2	neMESYS TxD	neMESYS RS232 transmit
3	Not connected			
4	Green	Pair 1	Gnd	RS232_Ground
5	Brown	Pair 2	Gnd	RS232_Ground
6	Black		Shield	Cable shield

Connector: Molex Micro-Fit 3.0.™ 6 poles (430-25-0600)

Crimp terminals: Molex Micro-Fit 3.0™ female crimp terminals (430-30-0010)

Hand crimper: Molex hand crimper (Europe: 69008-0983; America: 63811-2800)

## 6.6.3 Cable head B pin assignment

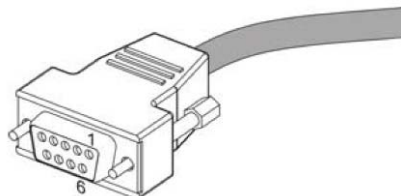

Figure 32 - Pin assignment RS232-COM cable head B

Pin No.	Color	Twisted wire	Signal	Description
1	Not connected			
2	White	Pair 2	RS232 RxD	COM RS232 receive
3	Yellow	Pair 1	RS232 TxD	COM RS232 transmit
4	Not connected			
5	Brown	Pair 2	RS232 Gnd	COM RS232_Ground
	Green	Pair 1	RS232 Gnd	COM RS232_Ground
6	Not connected			
7	Not connected			
8	Not connected			
9	Not connected			
x	Shield		Cable shield	Soldered on connector housing

Pin assignment according to RS-232 standard

Connector: Female D-Sub connector DIN 41652, 9 poles, with mounting screws

## 6.7 neMESYS OEM USB-to-CAN interface

### 6.7.1 Description

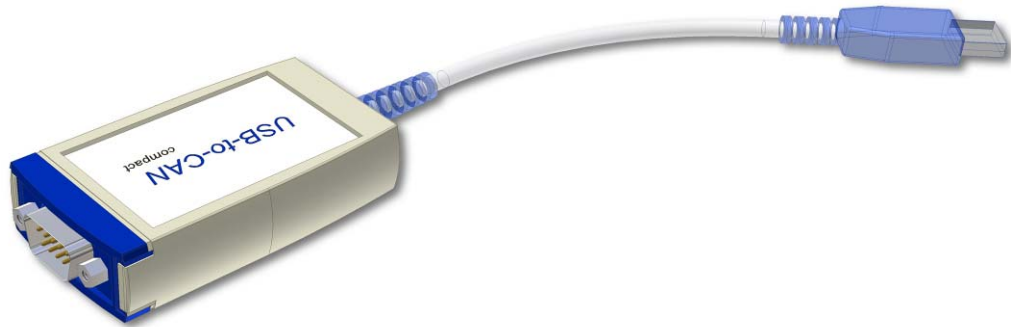

Figure 33 - neMESYS OEM USB-to-CAN interface



The USB-to-CAN compact interface has a CAN bus interface according to ISO 11898-2. The signals of the bus interface are connected to the 9-pin Sub-D connector.

The USB-to-CAN compact can be plugged in and unplugged during operation of the PC (Hot-plug compatible). A driver is required to operate the interface. For installation of the neMESYS tubing pump hardware device drivers, please refer to the software manual.



#### **IMPORTANT**

*Install the neMESYS hardware device drivers before plugging in the USB-to-CAN interface for the first time.*

Cable head A	Cable head B
 <p>Connect this cable end to the 9-pin Sub-D connector (cable head B) of the neMESYS OEM CAN cable (chapter 6.3) that is plugged into the first neMESYS OEM device.</p>	 <p>The USB connector is designed as type "A" connector. Pin allocation is according to the USB standard. Connect this cable end to your control PC.</p>

---

## 6.7.2 Cable head A pin Assignment

Pin No.	Signal	Description
1		
2	CAN low	CAN low bus line
3	CAN GND	CAN Ground
4		
5		
6		
7	CAN high	CAN high bus line
8		
9		

# 7 Installation and configuration

## 7.1 External wiring via CAN interface

### 7.1.1 Drawing

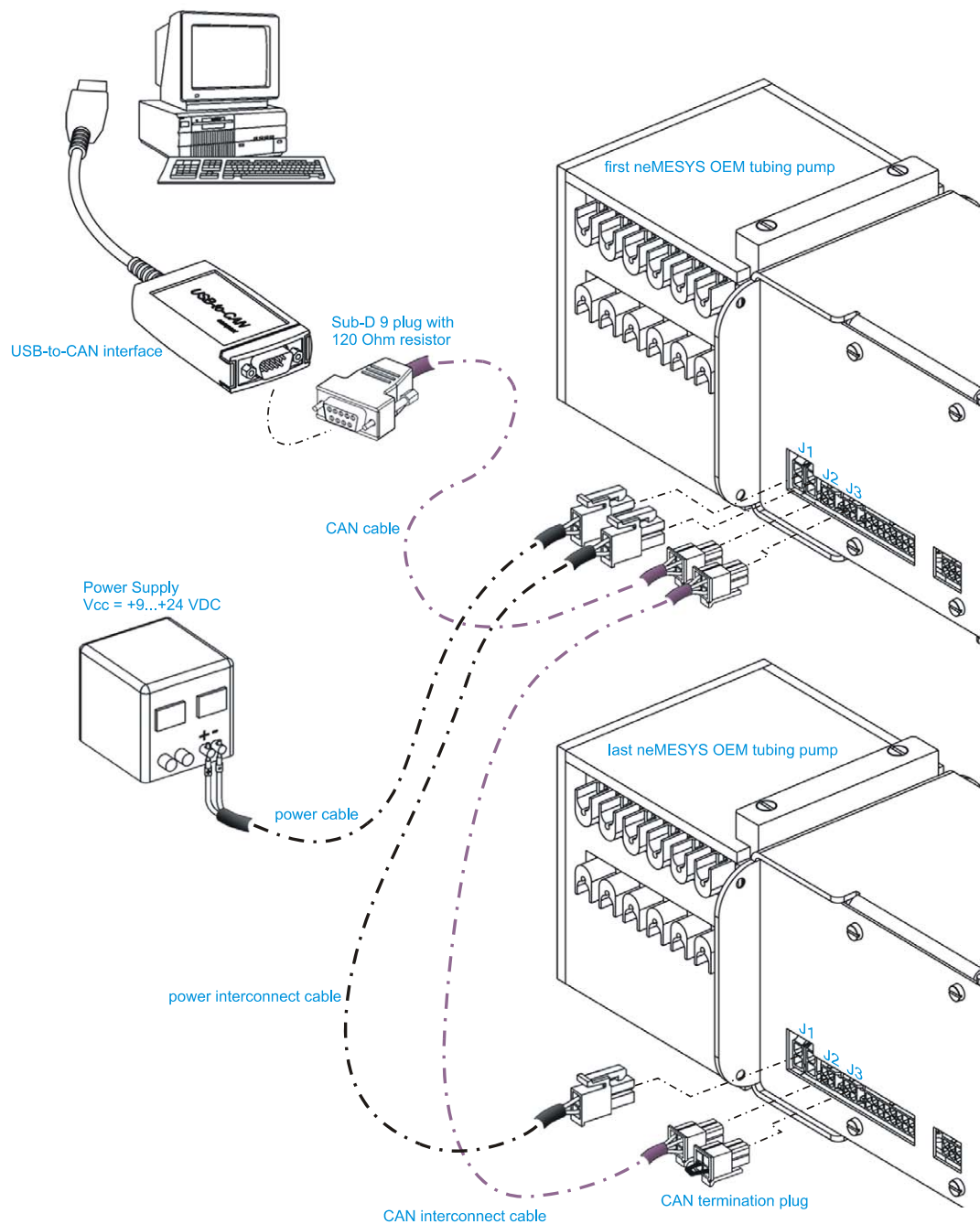

Figure 34 - neMESYS OEM tubing pump external wiring via CAN interface

---

## 7.1.2 Description

Install the neMESYS OEM hardware. Use the neMESYS cable assemblies below for wiring.

You should have:

- neMESYS OEM tubing pumps
- neMESYS OEM power cable
- neMESYS OEM power interconnect cable
- neMESYS OEM CAN cable
- neMESYS OEM CAN interconnect cable
- neMESYS OEM CAN termination plug
- neMESYS OEM USB-to-CAN interface

Follow the steps and see also Figure 34.

### Step 1 – Install neMESYS software and device drivers

Install the software from the neMESYS CD-ROM. The CD-ROM contains all necessary information and tools for installation and operation of the neMESYS OEM tubing pump (Manuals, Firmware, Tools and Windows DLLs, LabVIEW libraries).

The latest edition of the software for the neMESYS OEM tubing pumps may be downloaded from the internet under <http://www.cetoni.de> category *Service* → *Downloads*.

For a detailed description of the software installation procedure please refer to the neMESYS OEM tubing pump software manual.

### Step 2 – Connect neMESYS OEM power cable

Connect the power cable to the connector J1 of your first neMESYS OEM tubing pump. On the opposite side connect to a power supply (+9 ... +24 VDC). The necessary output current is depending on load (Continuous current for one module  $\approx 0.3$  A; acceleration, short-time max. current  $\approx 0.6$  A).



#### **NOTICE**

*Make sure that the supply voltage is between 9 and 24 VDC. Voltages higher than 27 VDC or of wrong polarity will destroy the unit.*

### Step 3 – Connect neMESYS OEM power interconnect cables

Connect the power interconnect cable with the second socket of connector J1 of the current neMESYS OEM pump. On the opposite side connect to the first socket of connector J1 of the next OEM tubing pump. You can chain up to 12 pumps together this way.

### Step 4 – Connect neMESYS OEM CAN cable

Connect the neMESYS OEM CAN cable to the CAN connector J2 of the first neMESYS OEM tubing pump. On the opposite side connect the Sub-D 9 female plug to the Sub-D 9 male connector of the USB-to-CAN interface.



#### **IMPORTANT**

*If you use the neMESYS OEM CAN cable then always connect it to the first device because the Sub-D 9 plug contains the 120 Ohm resistor for proper bus termination*



#### **IMPORTANT**

*If you do not use the neMESYS cable set then you should care about proper bus termination.*

### Step 5 – Connect neMESYS OEM CAN interconnect cables

Connect further neMESYS OEM pumps by using the neMESYS OEM CAN interconnect cables. Connect the CAN connector J3 of the first module with the CAN connector J2 of the next pump. The wiring-topology of a CAN-network should be as close as possible to a single line structure. You can connect up to 127 neMESYS OEM pumps to a single CAN bus using the CAN interconnect cables.

### Step 6 – Install CAN bus termination plug

The CAN bus data lines must be terminated at each end of the main bus with 120 ohm. The neMESYS OEM CAN cable already has a built in 120 ohm resistor and terminates one end of the bus. To terminate the second end of the bus, you need to plug the CAN termination plug into the CAN connector J3 of your last neMESYS OEM tubing pump.

### Step 7 – Connect USB-to-CAN interface

Connect the USB-to-CAN interface to an USB port of your control PC. The drivers should now get installed automatically. For a detailed description of the device driver installation procedure please refer to the neMESYS OEM tubing pump software manual.

## 7.2 External wiring via RS-232 interface

### 7.2.1 Drawing

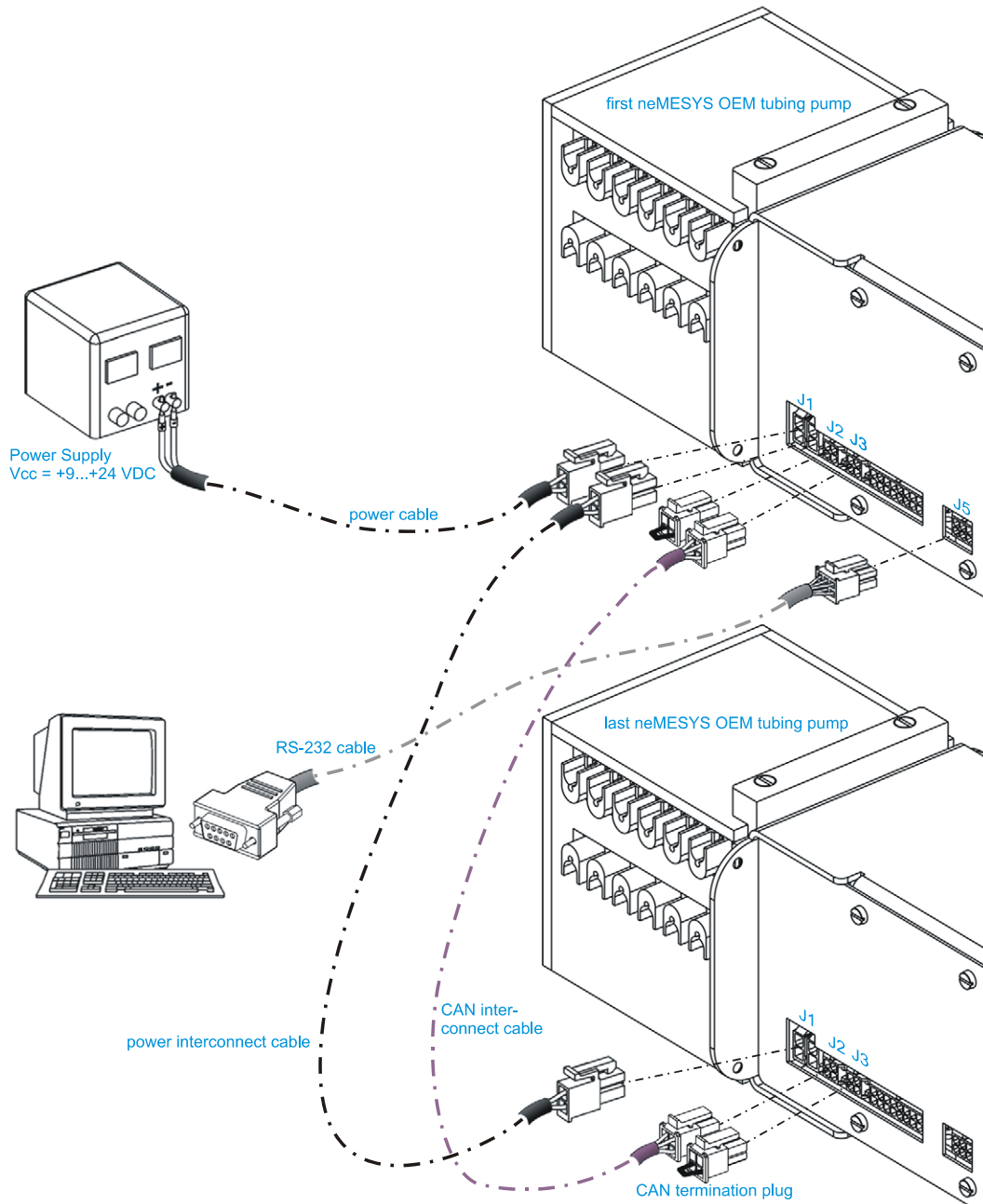

Figure 35 - neMESYS OEM tubing pump external wiring g via RS232 interface

## 7.2.2 Description

Install the neMESYS OEM hardware. Use the neMESYS cable assemblies below for wiring.

You should have:

- neMESYS OEM tubing pumps
- neMESYS OEM power cable
- neMESYS OEM power interconnect cable
- neMESYS OEM RS232 COM cable
- neMESYS OEM CAN interconnect cables
- neMESYS OEM CAN termination plugs

Follow these steps and see also Figure 35.

### Step 1 – Connect neMESYS OEM power cable

Connect the power cable to the connector J1 of your first neMESYS OEM tubing pump. On the opposite side connect to a power supply (+9 ... +24 VDC). The necessary output current is depending on load. (Continuous for one module max. 0.3 A; acceleration, short-time max. 0.6 A).



#### **NOTICE**

*Make sure that the supply voltage is between 9 and 24 VDC. Voltages higher than 27 VDC or of wrong polarity will destroy the unit.*

### Step 2 – Connect neMESYS OEM power interconnect cables

Connect the power interconnect cable with the second socket of connector J1 of the current neMESYS OEM pump. On the opposite side connect to the first socket of connector J1 of the next OEM pump. You can chain up to 12 pumps together this way.

### Step 3 – Connect neMESYS RS232-COM cable

Connect the neMESYS OEM RS232 COM cable to the RS232 connector J5 of the first neMESYS OEM tubing pump. On the opposite side connect the Sub-D 9 female plug to the Sub-D 9 male connector of your PC or microcontroller unit.

---

#### **Step 4 – Connect neMESYS OEM CAN interconnect cables**

Connect further neMESYS OEM tubing pump by using the neMESYS OEM CAN interconnect cables. Connect the CAN connector J3 of the first module with the CAN connector J2 of the next module. The wiring-topology of a CAN-network should be as close as possible to a single line structure. You can connect up to 127 neMESYS OEM pumps to a single CAN bus line using the CAN interconnect cables.

#### **Step 5 – Install CAN bus termination plugs**

The CAN bus data lines must be terminated at each end of the main bus with 120 ohm. To terminate both ends of the bus, plug a CAN termination plug into the CAN connector J2 of your first neMESYS OEM pumps and plug a second CAN termination plug into the CAN connector J3 of your last neMESYS OEM tubing pump.

### **7.3 CAN Bus Termination**

The CAN-Bus line has to be terminated at both ends with a termination resistor of typically 120  $\Omega$ . With the neMESYS CAN termination plug the bus can be terminated easily.

If a neMESYS OEM pump is the first device in the CAN network, plug the neMESYS CAN termination plug into the CAN connector J2. If you use the neMESYS OEM CAN cable you do not need to plug the termination plug into J2 because a 120  $\Omega$  resistor is already included in the Sub-D 9 connector of this cable. If a neMESYS OEM pump is the last module in the CAN network, plug the neMESYS CAN termination plug into CAN connector J3 of this device.

## 8 Tube fitting

### 8.1 Removing pump-head cover

You should switch the pump off, before you do any setup steps. Before you exchange cassettes or tubes you need to remove the transparent pump head cover. As soon as this pump cover is removed, the pump will stop pumping (in case you did not switch off the pump before).

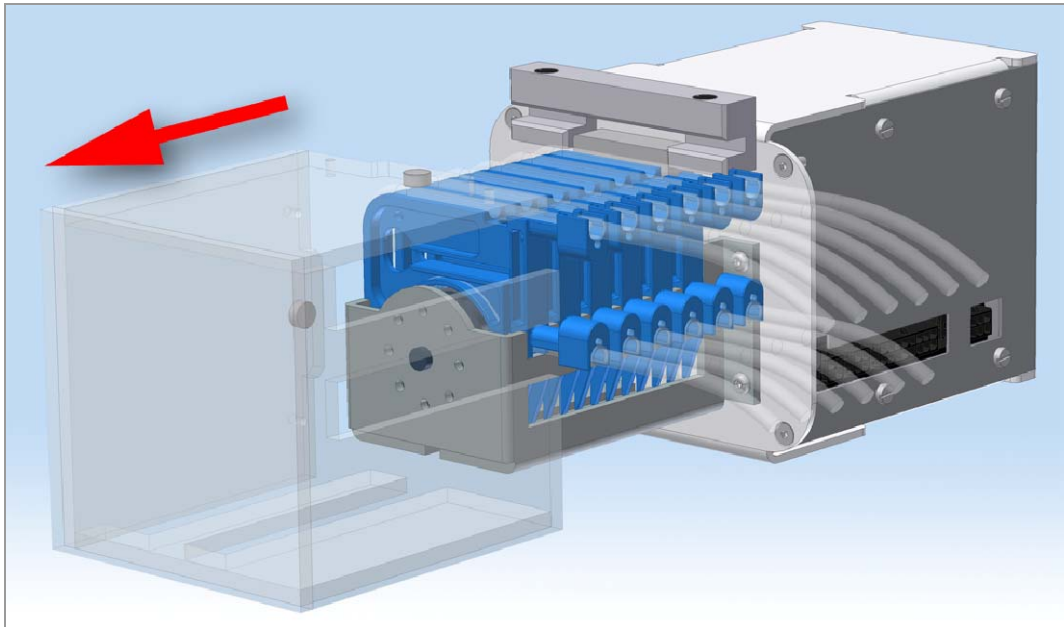

Figure 36 - Removing pump-head cover



#### **IMPORTANT**

*Pump operation is only enabled if the pump head cover is fitted to the pump. If the cover is removed, pump drive operation is blocked.*

## 8.2 Removing cassette from pump head

To remove a cassette from the pump head, you should switch off the pump first. Then remove the cassette by slightly pressing the fixing-tongue (see Figure 37) and lifting it simultaneously.

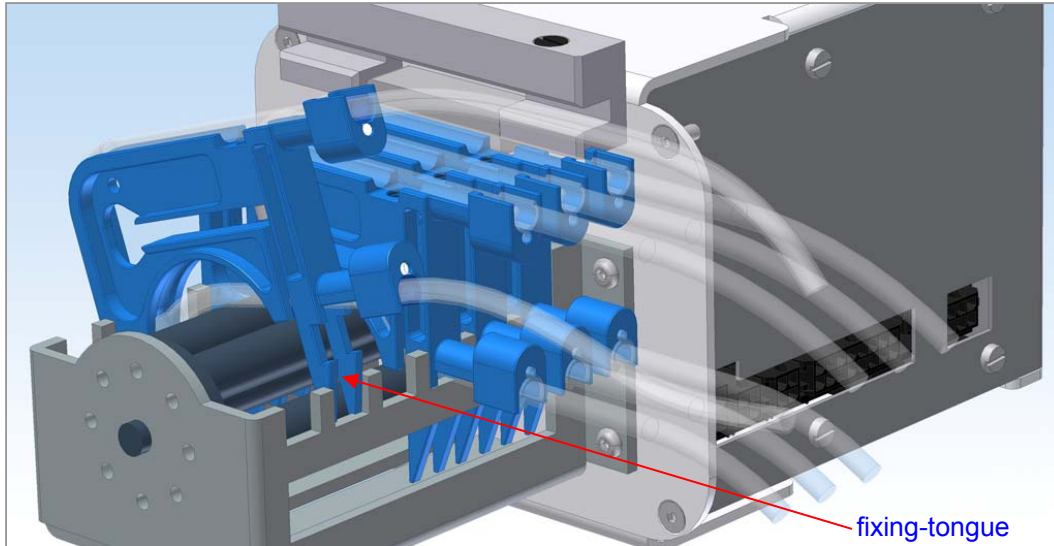
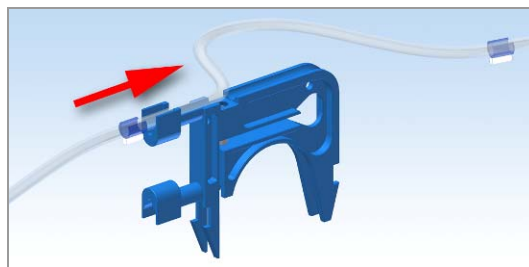

Figure 37 - Removing cassette from pump head

## 8.3 Inserting the tube

Please observe the following steps to fit a tube to a cassette:

- (1) Insert the 2-stop tubing with one stopper into the cassette like shown in the figure to the right. Move the stopper into the notch to fix it.
- (2) Lay the tube round the cassette and prevent it from being twisted.



- (3) Insert the second stopper of the tubing at the other end of the cassette.

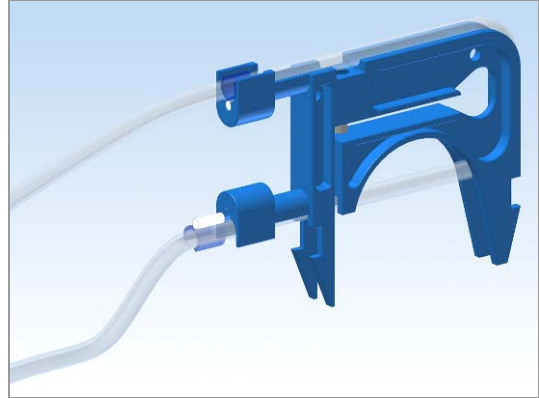

- (4) Move the stopper into the notch, like shown in the figure to the right, to fix it on the cassette.

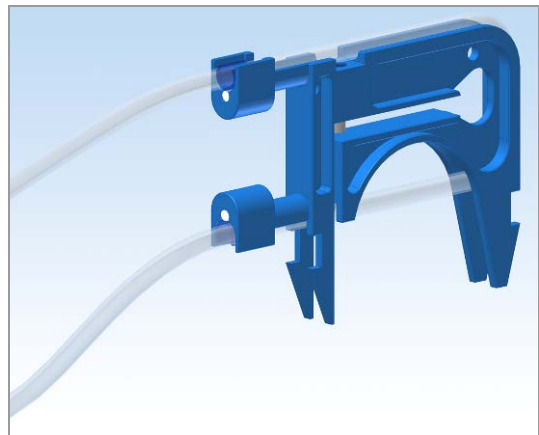

When you finished tube fitting, you can reinsert the cassette into the roller-head like shown in Figure 37.



**IMPORTANT**

*When the pump is idle for a longer amount of time, you should release all cassettes at the fixing tongue.*

## 8.4 Mounting the pump-head cover

Before you can use the pump, you need to mount the pump-head cover again. Mounting of the cover depends on the mounting-direction of the cassettes. The cassettes can be mounted in both directions. That means the tube outlets of the stopper tubes may point to the left or to the right side (Figure 38).

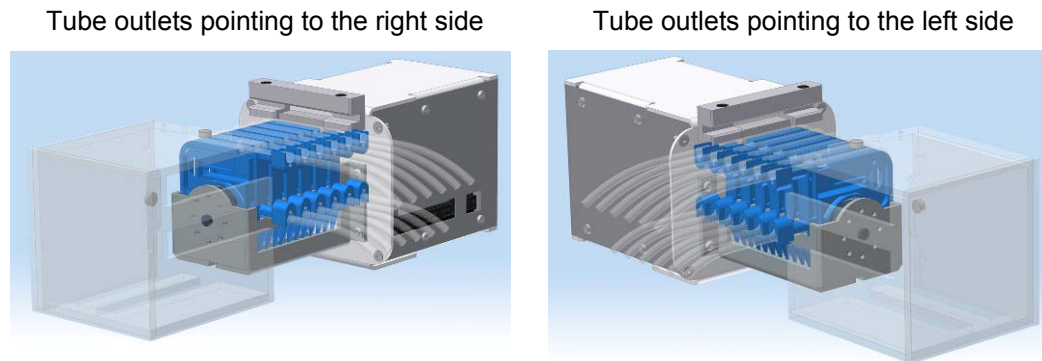

Figure 38 – Pump-head cover mounting

You may need to rotate the cover to fit it onto the pump head. To mount the cover move it towards the pump mounting panel plate until the two spring pins from the pump snap into the two notches on the topside of the cover.

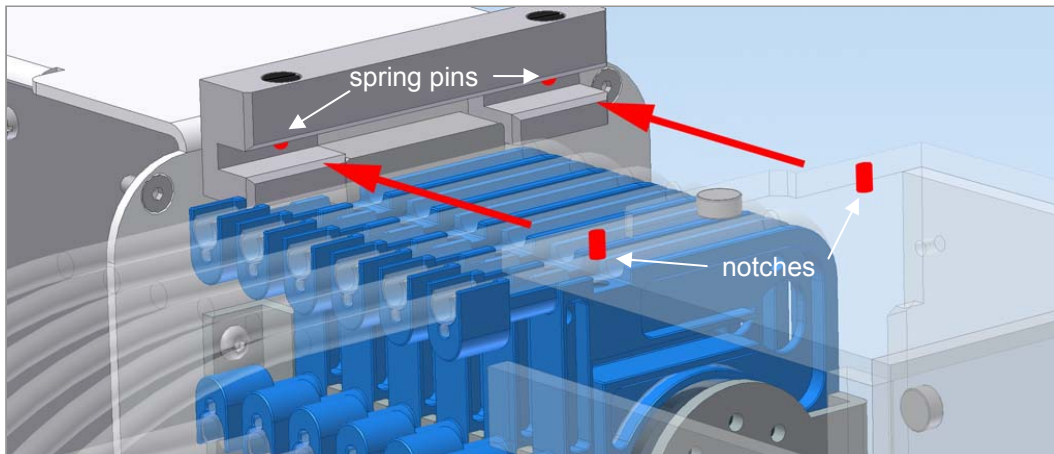
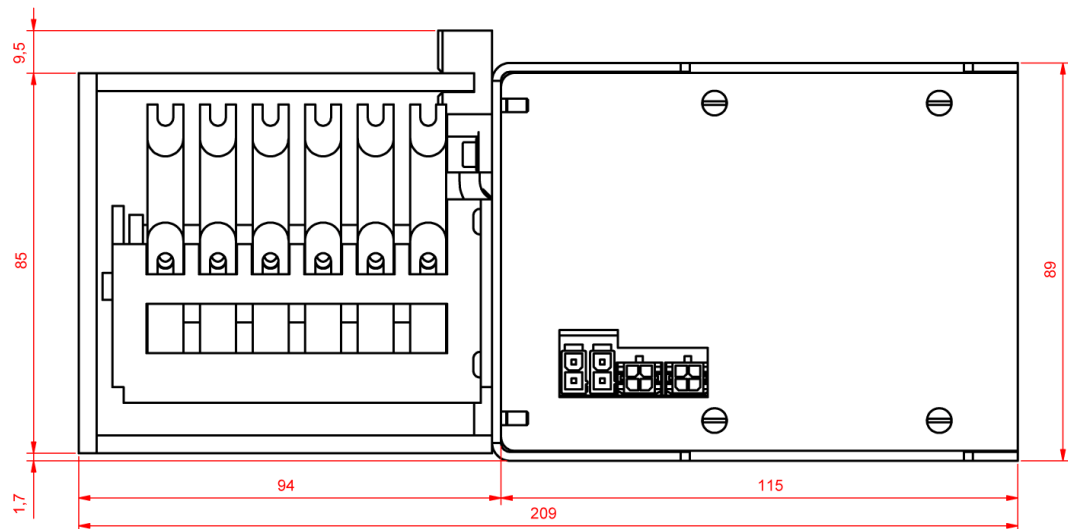

Figure 39 - Pump-head cover snap-in

# 9 Dimension drawing

Dimensions in [mm]

Side view (mm)



Front view (mm)

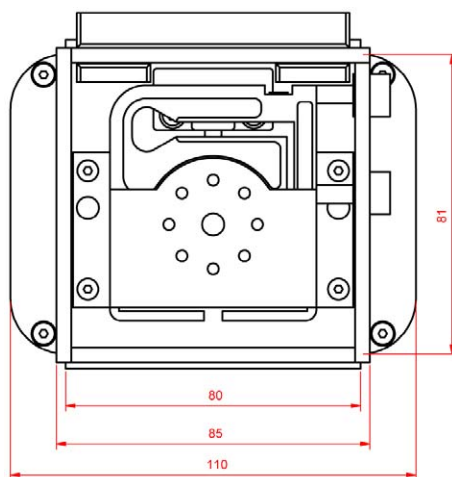

Mounting cut-out (mm)

