

NEMIX SYRINGE

Syringe Stirrer

Features

There are many applications where it is very important to stir various suspensions while dosing them. With the neMESYS Syringe Stirrer it is now possible to stir suspensions during the dosing process. The stirring is stress free for cells and homogenises your suspension so you can reach genuine results.

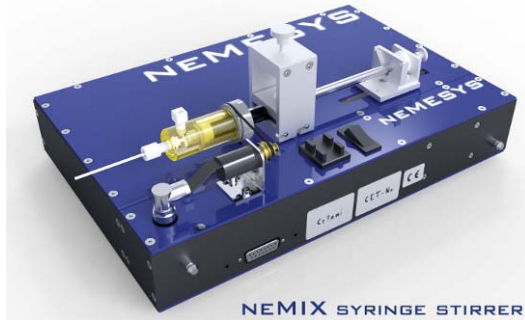

This system is available with a 2.5 ml syringe and a 5 ml syringe. It works only with the neMESYS syringe pump system

Mechanical Data

Weight of agitator 2.5ml / 5ml63 / 65 g
 Weight of driving module1080 g
 Dimensions (L x W x H)
 Agitator..... 162 x 28 x 28 mm
 Driving module 310 x 56 x 81 mm

Electrical Data

Power Supply Voltage..... 24 VDC

Materials

Bottle Tecason®E
 O-ring Silicone rubber (VMQ)

Environment / Handling

Operating Temperature..... -10°C to 45°C
 Storage Temperature..... -40°C to 80°C
 Operating Humidity 20% to 80%, non-condens.
 Storage Humidity 20% to 80%, non-condens.
 Autoclavability limited
 Sterilisation (70% alc.) yes
 Sterilisation (UV) yes

Configuration

Syringe to use ILS 2.5 or 5 ml (included)
 Min rotation speed* 60,8 rpm
 Max rotation speed* 1628,8 rpm

*Rotation Speed depends on viscosity

Dosing Performance with a neMESYS module

Gear	1,0	14,1*	23,7	29,2
Syringe stirrer 2.5 ml				
Flow Rate min (µl/min)	0,958	0,068	0,040	0,033
Flow Rate max (ml/min)	222,500	15,822	9,397	7,630
Dosing Vol. min (pl) = 1 step	203,450	14,468	8,593	6,977
Syringe stirrer 5 ml				
Flow Rate min (µl/min)	1,917	0,136	0,081	0,066
Flow Rate max (ml/min)	445,000	31,644	18,795	15,261
Dosing Vol. min (nl) = 1 step	406,900	28,935	17,186	13,954

*standard configuration

Mechanical Drawing

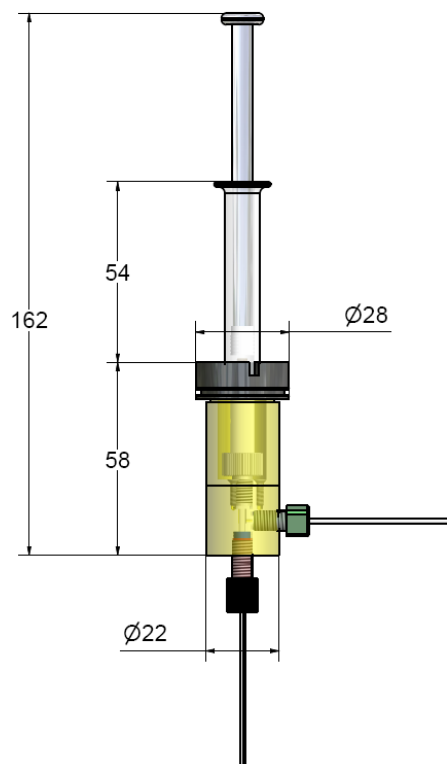

Notice

You can dose only a little bit more than a half of the volume of the syringe. We recommend to use a module type without a valve or to screw the valve off while using the neMIX Syringe Stirrer.