

CETONI

CE NEMESYS OEM 160/210 Hardware Manual

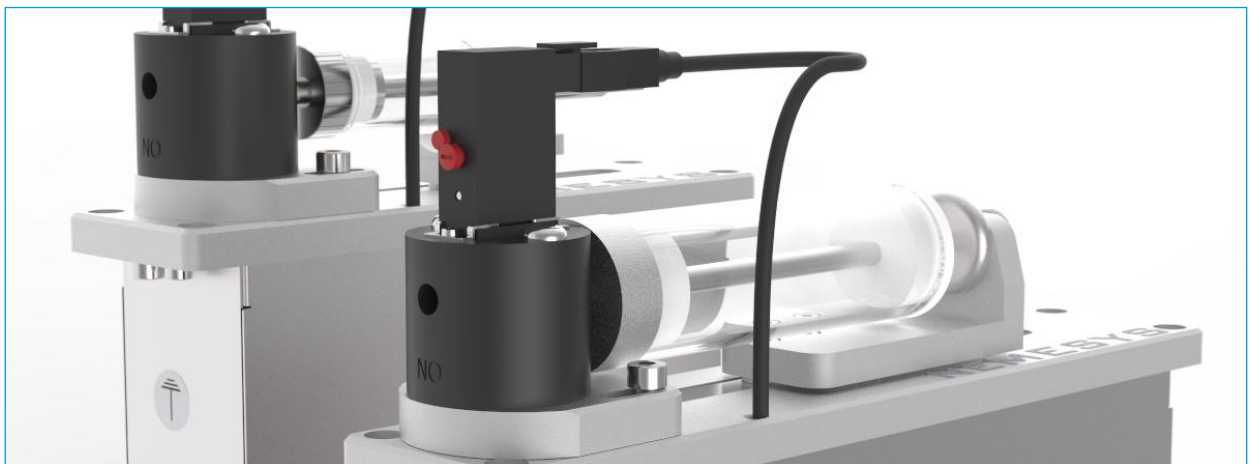

ORIGINAL SETUP AND OPERATING MANUAL 1.00 – NOVEMBER 2016

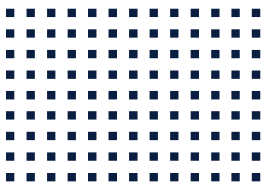

CETONI GmbH
Wiesenring 6
07554 Korbußen
Germany

T +49 (0) 36602 338-0
F +49 (0) 36602 338-11
E info@cetoni.de

www.cetoni.de

Software License

The software and the supplied documentation are copyrighted material. By installing the software you accept the terms of the licensing agreement.

License Agreement

CETONI GmbH grants the buyer the simple, non-exclusive and non-transferrable right to use the software on a single computer or networked computer system (LAN). Copying or any other duplication of the entire software or parts thereof or mixing and connecting it with other software products is expressly prohibited. For backup purposes the buyer may create a single copy of the software. CETONI GmbH reserves the right to alter, develop, improve or replace the software. CETONI is not obligated to inform the buyer with respect to modifications, new developments or improvements or to supply them to him. CETONI does not legally warrant any particular software properties. CETONI is not liable for any damage, unless it is caused willfully or due to gross negligence on the part of CETONI GmbH or its agents. Any liability for indirect, incidental or consequential damage is excluded.

The information and data contained in this document are subject to change without prior notice. No part of this document may be copied or transmitted without the express consent of CETONI GmbH, irrespective of the means used for this purpose – electronic or mechanical. The general terms of CETONI GmbH apply. Agreements deviating from these terms must be made in writing.

Copyright © CETONI GmbH – Automation and Microsystems. All rights reserved.

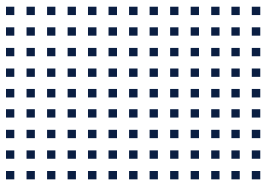

1 Overviews and Indexes

1.1 Content

1	Overviews and Indexes	5
1.1	Content	5
1.2	Revision History	8
2	Introduction	9
2.1	Preface	9
2.2	Symbols and Keywords	9
2.3	Standards and Guidelines	10
2.4	Intended Use	10
2.4.1	Proper Use	10
2.4.2	Reasonably Foreseeable Misuse	10
2.4.3	Safety Measures	11
2.4.4	Measures for Safe Setup	12
2.4.5	Safe Operation Measures	12
2.4.6	Safety Features on the Device	13
2.4.7	Condition of Devices	13
2.5	Warranty and Liability	13
2.6	Scope of Supply	14
3	Technical Data	16
3.1	Electrical Data	16
3.2	Ports and Connectors (electrical)	16
3.3	Mechanical Data	16
3.4	Ambient Conditions	16
3.5	Dimensions	17
3.6	Standard Valve	17
3.7	Dosing Capacity	18
3.8	Syringes	18

4	Transport and Storage	19
5	Hardware Operation	20
5.1	Installing a Syringe	20
5.2	Fluidic / Valve	21
5.3	Removing Valves	22
6	Electrical Interfaces	24
6.1	Overview	24
6.2	Power Supply (C1 / C2)	25
6.2.1	Pin Assignment	25
6.2.2	Technical Data	25
6.3	CAN Interface (C3 / C4)	26
6.3.1	Pin Assignment	26
6.3.2	Technical Data	26
6.3.3	Connecting neMESYS to CAN bus line CiA DS-102	27
6.4	RS-232 Connection (C6)	27
6.4.1	Pin Assignment	27
6.4.2	Technical Data	28
6.4.3	Connecting neMESYS OEM to a PC	28
6.5	Signal Connection (C5)	28
6.5.1	Technical Data	30
6.5.2	Analog Input 1 and 2 (Pin 1 and 2)	30
6.5.3	Digital Inputs 1 and 2 (Pin 3 and 4)	30
6.5.4	Digital Input 3 (Pin 5)	31
6.5.5	Digital Output 1, 2 and 3 (Pin 6, 7 and 8)	31
6.6	CAN-Bus Termination	33
6.7	Switching the Integrated Valve	33
7	Cable Set	34
7.1	Power Cable	34
7.2	Power Connection Cable	35
7.3	CAN Cable (terminated D-Sub Socket)	36

7.4	CAN Cable (D-Sub Plug)	37
7.5	CAN Connection Cable	38
7.6	CAN Terminator	39
7.7	RS-232 Cable (D-Sub Socket)	40
7.8	USB-to-CAN Adapter	41
8	Setup & Cable Connection	42
8.1	Mechanical Setup	42
8.2	Introduction to Cable Connection	42
8.3	Step 1 – Connecting the Power Cable	42
8.4	Step 2 – Data Connection	42
8.4.1	Data Connection through CAN	43
8.4.2	Data Connection through RS-232	43
8.5	Step 3 – Power Supply of Additional Modules	43
8.6	Step 4 – Data Connection to Additional Modules	43
8.7	Step 5 – CAN Bus Termination	44
9	Maintenance and Care	45
10	Disposal	46

1.2 Revision History

REV	DATE	MODIFICATION
1.00	11.11.2016	Creation of Manual

2 Introduction

2.1 Preface

Thank you for purchasing a CETONI product! This manual will support you in using the neMESYS OEM 160 and 210 syringe pump systems. If you have any questions or ideas, we would be happy to talk to you directly.

You should carefully read this manual before using the neMESYS OEM 160 or neMESYS OEM 210 syringe pumps. We wish you the best of success.

2.2 Symbols and Keywords

This manual uses the following symbols, intended to help you navigate the document:



HINT. User tips and useful information to simplify the use of the software.



IMPORTANT. Important information and additional, particularly useful information. This symbol does not refer to dangerous or hazardous situations.



CAUTION. This symbol signifies a potentially hazardous situation. Failing to avoid it may cause damage to the product or its environment.



WARNING. This symbol signifies a potentially dangerous situation. Failing to avoid it may cause light or insignificant injury or material damage.

2.3 Standards and Guidelines

Syringe pumps neMESYS OEM 160 and 210 conform to the basic health and safety requirements stipulated by the 2006/42/EC machine directive. The modules are incomplete machines according to the 2006/42/EC machine directive and intended for installation into a machine. According to the directive they do not bear the CE mark.

Integrating the modules into a machine may cause additional risks. It is imperative that you conduct a risk evaluation of your machine with the integrated modules and take any safety measures necessary.



IMPORTANT. Please note that you may not use syringe pumps neMESYS OEM 160 or neMESYS OEM 210 until the machine or plant into which the modules are integrated complies with the 2006/42/EC machine directive and the declaration of conformity in attachment II A has been issued.

2.4 Intended Use

The neMESYS OEM 160 and neMESYS OEM 210 syringe pumps were not designed to function as standalone devices. They are intended for integration into complex laboratory devices developed and built by the user. There they make it possible to fill and discharge syringes through linear movements between a syringe holder and a piston holder. In this way they enable highly precise and pulsation-free dosing of fluids in the range of nanoliters and milliliters per second.

The OEM-devices are not complete machines as stipulated by the machine guidelines. Instead, they are incomplete machines, intended for the integration into another machine or system. Please refer to the information in section 8 of this manual.

2.4.1 Proper Use

The neMESYS OEM 160 and neMESYS OEM 210 syringe pumps are intended for integration into a complex laboratory device and there they are used for filling and discharging syringes as well as dosing fluids.

2.4.2 Reasonably Foreseeable Misuse

Using the devices in applications other than the ones intended for them may create dangerous situations and must be avoided.



WARNING. The devices must not be used as medical devices or for medical purposes.

2.4.3 Safety Measures

Operator safety and failure-free operation of the devices can only be guaranteed when using original equipment parts. Only original accessories may be used. Warranty claims are void if damage was caused by using third-party equipment or third-party material.

The devices were developed and designed in such way as to largely rule out dangers, if used properly. Nevertheless, you should observe the following safety measures to rule out any residual danger.

- CETONI GmbH would like to point out the operator's responsibilities when using the device. Local laws and regulations relevant to using this device must be observed. In the interest of a safe work process the operator and user of the device is responsible for observing all relevant laws and regulations.
- The device is designed and approved for operation in systems governed by article 4 section 3 of the pressurized devices directive 2014/68/EU. This means that the devices may not exceed a maximum volume of 1 liter. When using group 1 fluids according to article 13 of the pressurized systems directive 2014/68/EU, the maximum allowable system pressure is 200 bar. It is 1000 bar for group 2 fluids. If maximum pressure indications in section 3 contain different product-specific values, such values need to be adhered to. In particular, when creating complex systems by connecting peripheral devices, the pressure ranges of the individual devices (valves, sensors, syringes, fittings, hoses, etc.) must be observed and may not be exceeded. The weakest component determines the maximum pressure for the entire system. With respect to the maximum operating temperature, please observe the instructions provided in section 3. CETONI does not accept liability for any effects caused by users extending the system by adding peripheral devices to such an extent that one or both values are exceeded. The operator is responsible for becoming acquainted with the aforementioned pressurized systems directive and observing applicable stipulations.
- Before each operation of the device the user has to ensure that the device is functioning safely and is in proper condition.
- The user must be familiar with the operation of the device and the software.
- Before starting operation, the devices and wiring must be checked for damage. Damaged wires and plugs must be replaced immediately.
- Cables must be routed in such way as to rule out any trip hazards.

- Do not touch moving parts on the devices during operation. There is a risk of crushing.
- Operating the devices in an explosive environment or with explosive substances is prohibited!
- Make sure to wear safety goggles during installation work on the device or when you work with corrosive, hot or otherwise dangerous substances.
- Transport, storage or operation at temperatures below 0°C with water in the fluid channels may cause damage to the devices.

2.4.4 Measures for Safe Setup

- Mechanical and electrical installation of pumps neMESYS OEM 160 and neMESYS OEM 210 may only be done by skilled personnel.
- Make sure that all devices are installed in line with local laws and regulations.
- Please note that, principally, the OEM-pumps cannot be considered fail-safe. You have to ensure that a failing pump will not cause damage to your application by employing suitable safety and monitoring measures.
- Please note that you are not authorized to repair CETONI devices or components.
- Make sure that the power supply is not active and cannot be activated while conducting installation or wiring work on the devices.

2.4.5 Safe Operation Measures

2.4.5.1 ELECTRONIC EMISSIONS

The neMESYS OEM 160 and neMESYS OEM 210 syringe pump systems are designed for usage in any facility directly connected to a public supply network that also supplies buildings used for residential purposes.

2.4.5.2 ESD-DISCHARGE

Floors should be wood or concrete or covered with ceramic tiles. If floors are covered with synthetic material, relative air humidity must be at least 30%.

2.4.5.3 ELECTRICAL DISTURBANCES

Supply voltage quality should be equal to a typical business or hospital environment.

2.4.5.4 MAGNETIC DISTURBANCES

Power lines, including those of other devices, should not be placed near the device or its cables. Mobile two-way radios should be kept at the minimum safe distance from the device and its wiring.

2.4.6 Safety Features on the Device

As OEM-devices syringe pumps themselves do not include any mechanical or electrical safety features. The safety concept can be implemented only in the superior laboratory device, which contains the syringe pumps as a sub-system. The responsibility for this rests with the manufacturer of the laboratory device.

2.4.7 Condition of Devices

Despite flawless workmanship, the devices may be damaged during operation. Therefore, you should visually inspect the device components mentioned before each use. Pay particular attention to crushed cables, damaged hoses and deformed plugs. If you find any damage, please refrain from using the devices and contact CETONI GmbH immediately. We will repair your devices as soon as possible. Never attempt to repair a device yourself.

2.5 Warranty and Liability

The devices leave our facilities in perfect condition and may only be opened by CETONI GmbH. If a device is opened by an unauthorized person, all warranty and liability claims shall be void, in particular those referring to personal injury.

The warranty period is 1 year from the day of delivery. Any work done on the devices within this period shall not extend or renew the warranty.

CETONI GmbH assumes responsibility for its devices with respect to safety, reliability and function only if installation, readjustment, changes, extensions and repairs are done by CETONI GmbH or an authorized party, and if the devices are used in accordance with the user manual.

The neMESYS OEM 160 and neMESYS OEM 210 syringe pump systems comply with the applicable safety rules and standards. CETONI GmbH reserves all property rights for the relevant wiring, processes, names, software and devices.

2.6 Scope of Supply

Your device should be delivered with the following items:

NEMESYS OEM 160

OR

NEMESYS OEM 210

(depending on your order)

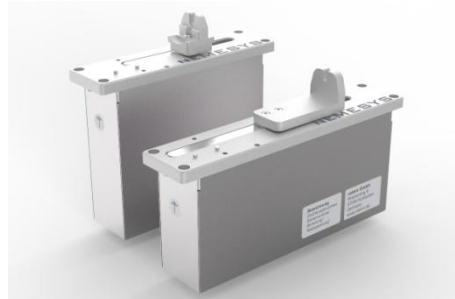

VALVE

(depending on your order)



CABLE SET

(depending on your order)



CD-ROM WITH SOFTWARE

(depending on your order)



HARDWARE MANUAL



3 Technical Data

3.1 Electrical Data

SUPPLY VOLTAGE	24 VDC
CURRENT TYPICAL / (PEAK)	0,3 A / (0,7A)

3.2 Ports and Connectors (electrical)

Please refer to section 6 Electrical Interfaces.

3.3 Mechanical Data

	NEMESYS OEM 160	NEMESYS OEM 210
DIMENSIONS (WITH VALVE) (L x W x H)	160 x 44 x 192 mm	210 x 44 x 160 mm
WEIGHT (WITH VALVE)	0,96 kg	1,06 kg

3.4 Ambient Conditions

OPERATING TEMPERATURE	0°C to 45°C / 32 °F to 113 °F
STORAGE TEMPERATURE	-40°C to 85°C / -40 °F to 185 °F
OPERATING AND STORAGE AIR HUMIDITY	20 % to 80 %, non-condensing

3.5 Dimensions

NEMESYS OEM 160

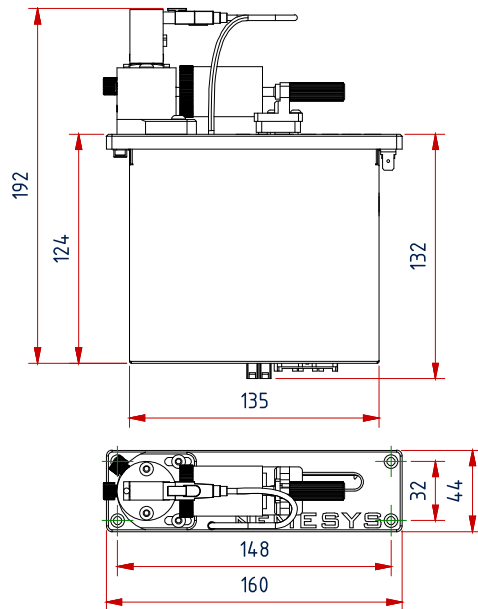

NEMESYS OEM 210

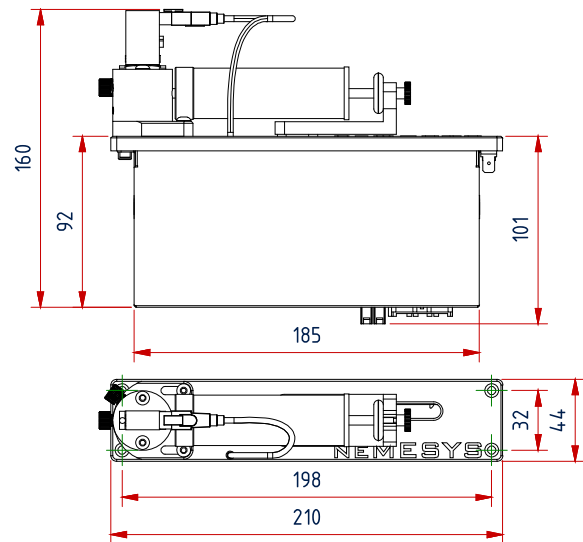

3.6 Standard Valve

TYPE	Bürkert 6144
HOUSING MATERIAL	PPS
SEALING MATERIAL	FKM
FLUID TEMPERATURE	0 °C to 50 °C / 32 °F to 122 °F
VISCOSITY MAX.	21 mm ² /s
INTERNAL VOLUME	approx. 45 µl
PRESSURE MAX.	10 bar
NOMINAL WIDTH	0,6 mm
FLUIDIC CONNECTIONS	1/4"-28 UNF

On request more valves and material combinations for housing and seal materials are available. Please contact us. We help you to find a solution for your specific application.



CAUTION. Risk of damage to the housing or the seal! Check and compare before the first use of the valve the chemical compatibility of the media that you want to pump with the housing material PPS and the sealing material FKM.

3.7 Dosing Capacity

The table below provides an overview of the minimum and maximum dosing speeds as well as the resulting flow rates, using the example of a 0.5 ml syringe with a 30mm stroke, mounted to a neMESYS OEM 160, or a 1 ml syringe with a 60mm stroke mounted to a neMESYS OEM 210. When speeds and flow rates fall below values referred to as “pulsation-free”, dosing precision decreases gradually.

VELOCITY MIN. [$\mu\text{m}/\text{min}$]		0,071
VELOCITY WITHOUT PULSATION MIN. [$\mu\text{m}/\text{min}$]		62,5
VELOCITY MAX. [mm/s]		6,33
neMESYS OEM 160 with 0,5 ml syringe with 30 mm piston stroke neMESYS OEM 210 with 1 ml syringe with 60 mm piston stroke	FLOW MIN. [$\mu\text{l}/\text{min}$]	0,0012
	FLOW WITHOUT PULSATION MIN. [$\mu\text{l}/\text{min}$]	1,042
	FLOW MAX. [ml/min]	6,33

3.8 Syringes

The following syringes are specified for usage in neMESYS OEM 160 and neMESYS OEM 210 devices.

	NEMESYS OEM 160	NEMESYS OEM 210
STROKE [mm]	30	60
MAX. VOLUME [ml]	12.5	25
MAX. DIAMETER [mm]	28	28
OUTSIDE THREAD OF CONNECTING CYLINDER	1/4"-28 UNF	1/4"-28 UNF
INSIDE THREAD OF CONNECTING PISTON	6-32 UNC	M3

4 Transport and Storage

Use the original packaging for transporting and shipping neMESYS OEM 160 and neMESYS OEM 210 syringe pumps.

Also observe the data provided in section 3.4.

5 Hardware Operation

5.1 Installing a Syringe

The neMESYS OEM 160 and neMESYS OEM 210 syringe pumps have been designed for mounting syringes according to the table shown in section 3.8.



IMPORTANT. Use high-quality glass syringes to ensure precise flow rates.

Before installing a syringe component, it can be configured and selected in the software. The procedure is described in the software manual. You will need the Scale Volume, the Scale Length and any differing Piston Stroke.

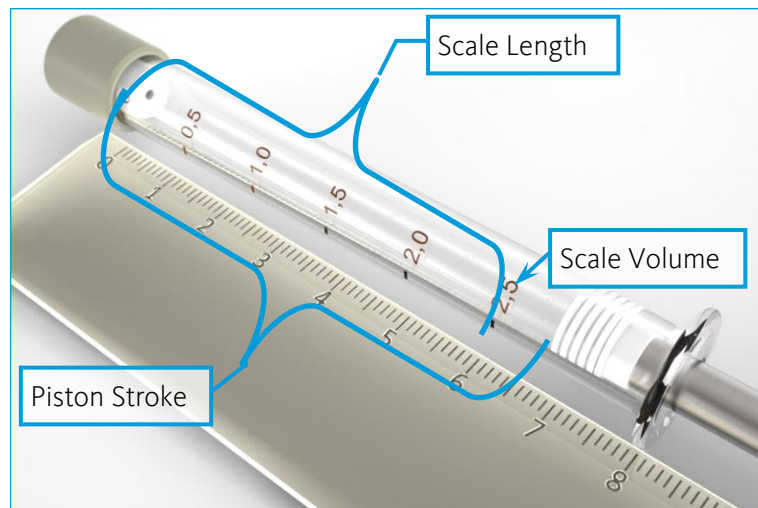

First, pull back the piston holder to a sufficient position. Screw the syringe into the valve base (thread: 1/4"-28 UNF). Now, carefully advance the piston holder toward the piston connector and connect both parts using the provided knurled screw 6-32 UNC (neMESYS OEM 160) or M3 (neMESYS OEM 210) respectively.

To compensate for small deviations of syringe geometry, there is a possibility to move the entire valve unit lengthwise. To do this, loosen both screws holding the valve unit in place, using a 3mm Allen wrench. Now adjust the position and re-tighten the screws.

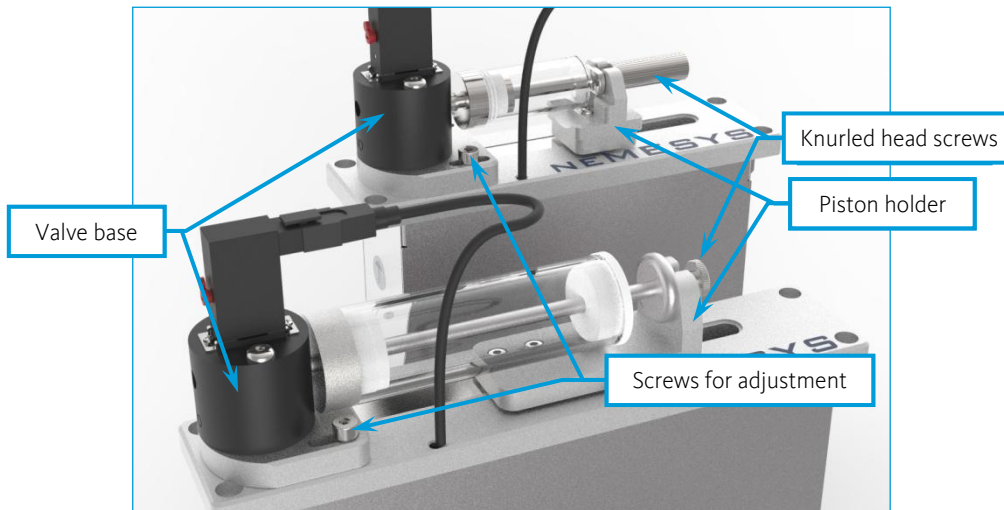

IMPORTANT. Syringes and seals in particular, are wear and tear parts. Please check them on a regular basis and replace them if necessary.

5.2 Fluidic / Valve

The syringe pumps neMESYS OEM 160 und neMESYS OEM 210 require a valve for the intended function. This valve allows you to switch the syringe connector between a reservoir (inlet) and your application (outlet), thereby enabling automatic refilling of the syringe without plugging the tubes. In the software you can adjust the valve in a way that it automatically switches to the inlet when filling the syringe.

In the valve's resting position the discharge port leading to the application is open. It is located at the center of the valve base coaxial to the port of the syringe and is marked with NO. At the same time the intake from the reservoir is closed. It is located on the right side of the valve base when viewed from above and in flow direction, is marked with NC and only opens while the syringe is filled.

It can be assumed that the time needed for picking up medium is very short when compared to the time required for discharging it. Therefore, the valve remains in its resting position most of the time. This significantly reduces power consumption and valve heating.

Please note, that the valve assembly is not included in the basic equipment of the syringe pumps neMESYS OEM 160 and neMESYS OEM 210. It has to be ordered separately according to the application. The valve assembly can be installed by the user by means of the two button head screws M4, which are prepared on the syringe pump.

Different valves are possible in combination with valve bases made of different materials. Please contact us, we will be pleased to advise you.

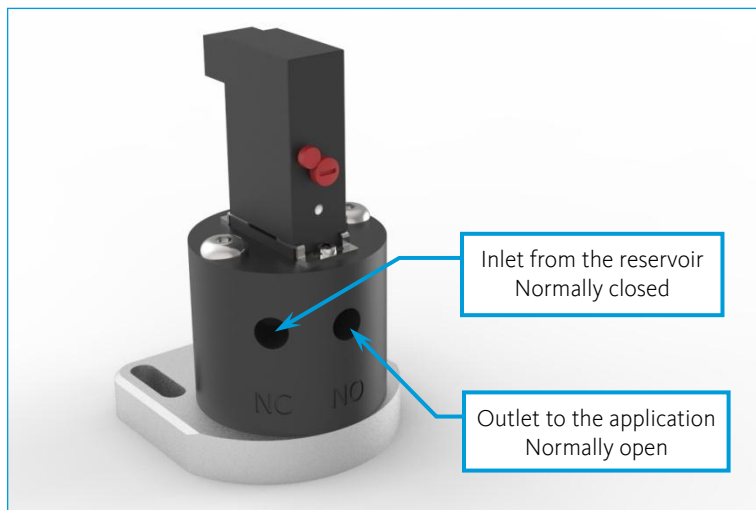

The connections on the valve base use 1/4"-28 UNF inside threads and therefore allow the use of widely available HPLC fittings.



CAUTION. Please note the maximum operating pressure of 10 bar to avoid damage to the standard valve.



CAUTION. Before using the valve please check the chemical resistance of the PPS housing material and the FKM sealing material with respect to the fluid you are planning to dose in your application.

5.3 Removing Valves

For cleaning or replacement in case of a defective the valve can be removed from the device in a few easy steps.

First pull out the connector. To do that, push down the snap-fit rocker to unlock it. When you re-attach the plug later, make sure it's in the correct position. The snap-fit rocker points upwards.

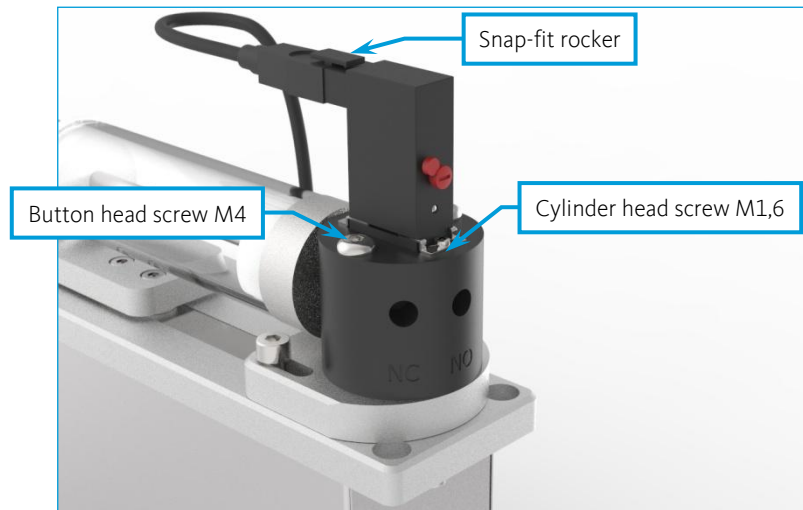

CAUTION. Please note the correct placement of the valve plug. The snap-fit rocker points upwards.

Remove two cylinder head screws M1,6 on the valve mounting plate. Now you can remove the valve upwards.

The new or cleaned valve is installed in reverse order. Please make sure not to damage or move the sealing on the bottom of the valve during installation. Carefully tighten the cylinder head screws, so as not to damage the plastic thread in the valve base.

If you also want to replace the valve base, you need to remove the two button head screws M4. The screws have to be mounted again after the exchange of the valve base. It is recommended not to tighten the screws first, but first reinstall the syringe and align the piston with its holder. In doing so, the valve base is given the correct orientation in its cylindrical socket. Finally the two button head screws M4 are fixed.

6 Electrical Interfaces

6.1 Overview

All interfaces (C1 through C7) for power supply, connecting a PC or an external controller and status LEDs (L1 through L9) for some connections are located on the bottom of the syringe pumps. The interface is identical for both the neMESYS OEM 160 and the neMESYS OEM 210 devices.

The following interfaces are available.

CONNECTOR	INTERFACE
C1 / C2	Power supply 24 VDC In / Out
C3 / C4	CAN Interface In / Out
C5	I/O Signal Interface
C6	RS-232 Interface
C7	Shield

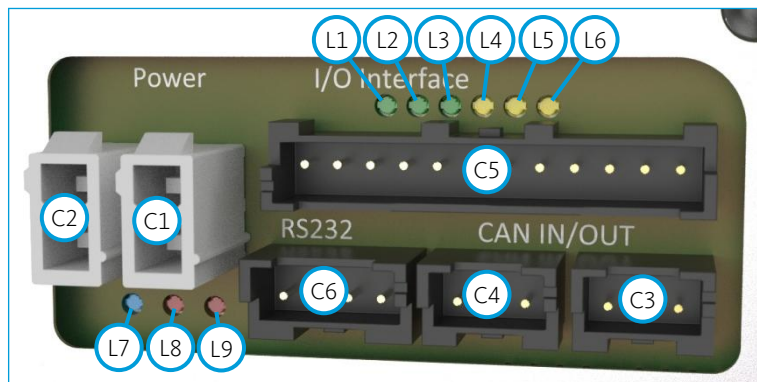

6.2 Power Supply (C1 / C2)

6.2.1 Pin Assignment

PIN NO.	SIGNAL	DESCRIPTION
1	Ground	Grounding of supply voltage
2	+Vcc	Supply voltage +24 VDC
LED	STATE / EXPLANATION	
L7	Lights up blue when the power supply is on.	
L8	Lights up red when the device fuse may be defective. (Please contact CETONI to arrange further action.)	
L9	Lights up red when the fuse of the controller may be defective. (Please contact CETONI to arrange further action.)	

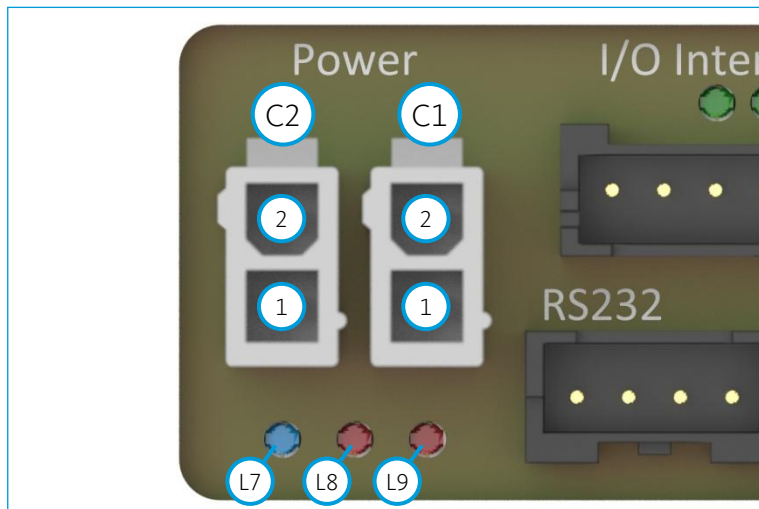

6.2.2 Technical Data

POWER SUPPLY REQUIREMENTS

OUTPUT VOLTAGE 24 VDC

OUTPUT CURRENT

Depends on power load and number of modules
 Typical current draw of one module: 0.3 A
 Surge current draw of one module: 0.6 A

INFORMATION REGARDING CONTACTS

PLUG CONNECTORS

Molex Mini-Fit Jr. 39012020

6.3 CAN Interface (C3 / C4)

6.3.1 Pin Assignment

PIN NO.	SIGNAL	DESCRIPTION
1	CAN_H	CAN high bus line
2	CAN_L	CAN low bus line
3	CAN_GND	CAN ground

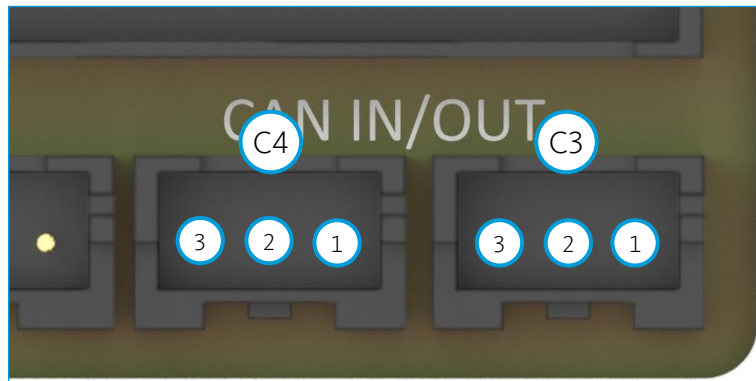

6.3.2 Technical Data

STANDARD TYPE	CAN high-speed, ISO 11898 compatible
MAXIMUM BIT RATE	1 Mbit/s
PROTOCOL	CANopen DS-301, DS-402
NODE ID	Software

INFORMATION REGARDING CONTACTS

PLUG CONNECTORS	JST Socket XAP-03V-1
CRIMP CONTACTS	JST Crimp socket SXA-001T-P0.6
CRIMP TOOL	JST WC-691 / WC-692

6.3.3 Connecting neMESYS to CAN bus line CiA DS-102

NEMESYS OEM	CAN 9 PIN D-SUB (DIN 41652)
Pin 1 "CAN_H"	Pin 7 "CAN_H" high bus line
Pin 2 "CAN_L"	Pin 2 "CAN_L" low bus line
Pin 3 "CAN_GND"	Pin 3 "CAN_GND" ground
Housing "CAN_Shield"	Pin 5 "CAN_Shield" cable shield



IMPORTANT.

- Please note the maximum Baud rate of your CAN master.
- The standard Baud rate at the time of shipping is 1 Mbit/s.
- The CAN bus must be terminated with two termination resistors (see section 6.6).

6.4 RS-232 Connection (C6)

6.4.1 Pin Assignment

PIN NO.	SIGNAL	DESCRIPTION
1	neMESYS TxD	neMESYS RS-232 transmit
2	neMESYS RxD	neMESYS RS-232 receive
3	GND	RS-232 ground
4	Shield	RS-232 shield

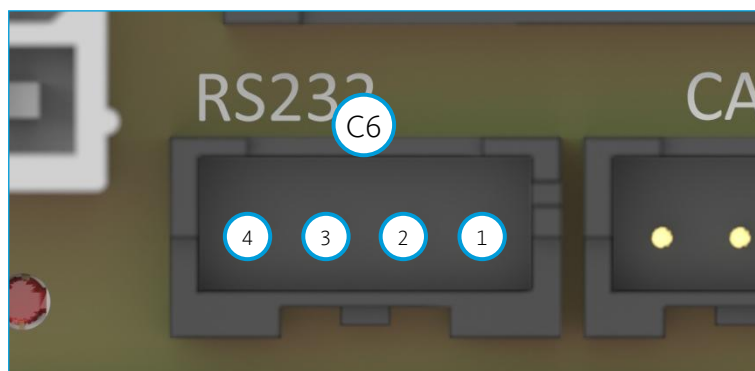

6.4.2 Technical Data

MAXIMUM INPUT VOLTAGE	± 30 V
OUTPUT VOLTAGE	typically ± 9 V @ 3k grounded
MAXIMUM BIT RATE	115.200 bit/s (standard 38.400 bit/s)
INTERNAL RS-232 DRIVER/RECEIVER	EIA RS-232 standard
INFORMATION REGARDING CONTACTS	
PLUG CONNECTORS	JST Socket XAP-04V-1
CRIMP CONTACTS	JST Crimp Socket SXA-001T-P0.6
CRIMP TOOL	JST WC-691 / WC-692

6.4.3 Connecting neMESYS OEM to a PC

NEMESYS OEM RS-232 (JST)	CAN 9 PIN D-SUB (DIN 41652)
Pin 1 "neMESYS TxD"	Pin 2 "PC RxD"
Pin 2 "neMESYS RxD"	Pin 2 "PC TxD"
Pin 3 "GND"	Pin 5 "GND"
Pin 4 "Shield"	Cover



IMPORTANT. Please note the maximum Baud rate of the RS232 interface on your PC or micro controller. The standard Baud rate setting is 115200 bit/s.

6.5 Signal Connection (C5)

PIN NO.	SIGNAL	LOGICAL NAME	DESCRIPTION
1	AnIN 1	Analog Input 1	Analog input 1 (0 – 5V)
2	AnIN 2	Analog Input 2	Analog input 2 (0 – 5V)
3	DigIN 1	General Purpose InA	Digital input 1 "multi-purpose"
4	DigIN 2	General Purpose InB	Digital input 2 "multi-purpose"

5	DigIN 3	General Purpose InC	Digital input 3 “multi-purpose”
6	DigOUT 1	General Purpose OutC	Digital output 1 “multi-purpose” / valve voltage
7	DigOUT 2	General Purpose OutD	Digital output 2 “multi-purpose” / valve switching
8	DigOUT 3	General Purpose OutA	Digital output 3 “multi-purpose”
9	GND		Digital signal ground
10	+24 VDC		Auxiliary voltage output 24 VDC
11	+5 VDC		Auxiliary voltage output 5 VDC
12	AGND		Analog-signal ground
LED	STATE / EXPLANATION		
L1	Lights up green when DigIN 1 = high		
L2	Lights up green when DigIN 2 = high		
L3	Lights up green when DigIN 3 = high		
L4	Lights up green when DigOUT 1 = low		
L5	Lights up green when DigOUT 2 = low		
L6	Lights up green when DigOUT 3 = low		



6.5.1 Technical Data

INFORMATION REGARDING CONTACTS

PLUG CONNECTORS	JST Socket XAP-12V-1
CRIMP CONTACTS	JST Crimp socket SXA-001T-P0.6
CRIMP TOOL	JST WC-691 / WC-692

6.5.2 Analog Input 1 and 2 (Pin 1 and 2)

As a standard, analog inputs are defined as “general purpose” and can be configured through the software.

ANIN1	Pin 1
ANIN2	Pin 2
A_GND	Pin 12
INPUT VOLTAGE RANGE	0 ... 5 VDC
INPUT VOLTAGE MAXIMUM	0 ... 5 VDC
INPUT RESISTANCE	>10 M Ω to A_GND (PIN 12)
A/D CONVERTER	11-bit
RESOLUTION	2,49 mV
BANDWIDTH	250 Hz

6.5.3 Digital Inputs 1 and 2 (Pin 3 and 4)

“Multi-purpose” inputs can be freely configured and utilized by the user.

DIGIN1	Pin 3
DIGIN2	Pin 4
GND	Pin 9
TYPE OF INPUT	Single ended

INPUT VOLTAGE	0 ... 30 VDC
MAXIMUM INPUT VOLTAGE	-30 ... +30 VDC
LEVEL LOW	typically < 0,8 VDC
LEVEL HIGH	typically > 2,0 VDC
INPUT RESISTANCE	typically 5,5 kΩ @24 V; 5,5 kΩ @5 V
INPUT CURRENT AT LEVEL HIGH	typically 0,8 mA @ 5 VDC
SWITCHING DELAY	< 300 μs

6.5.4 Digital Input 3 (Pin 5)

“Multi-purpose” inputs can be freely configured and utilized by the user.

DIGIN3	Pin 5
GND	Pin 9
TYPE OF INPUT	Single ended
INPUT VOLTAGE	0 ... 28 VDC
MAXIMUM INPUT VOLTAGE	-16 ... +28 VDC
LEVEL LOW	typically < 1,8 VDC
LEVEL HIGH	typically > 4,5 VDC
INPUT RESISTANCE	typically 49 kΩ to GND (Pin 9)
MAXIMUM INPUT FREQUENCY	2,5 MHz

6.5.5 Digital Output 1, 2 and 3 (Pin 6, 7 and 8)

Outputs 1 and 2 are used to switch the valve (refer to section 6.7). If the valve is not used, the outputs can be configured and used as general purpose outputs by the user.

DIGOUT1	Pin 6
DIGOUT2	Pin 7

DIGOUT3	Pin 8
GND	Pin 9
CIRCUIT	NPN Open Collector (internal pull-up-resistor 10kΩ)
SWICHTING DELAY	< 3 μs

6.5.5.1 WIRING EXAMPLES

DIGOUT “DRAIN”

MAXIMUM INPUT VOLTAGE	+30 VDC
MAXIMUM LOAD CURRENT	1 A
MAXIMUM VOLTAGE DROP	< 50 mV @ 1 A

DIGOUT “SOURCE”

OUTPUT VOLTAGE	$U_{out} \approx 24\text{ V} - (I_{load} \times 10\text{ k}\Omega)$
MAXIMUM LOAD CURRENT	$I_{load} \leq 2,4\text{ mA}$ (accidental ground)

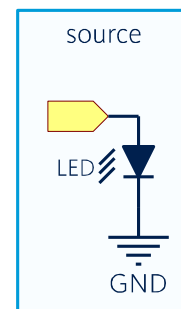
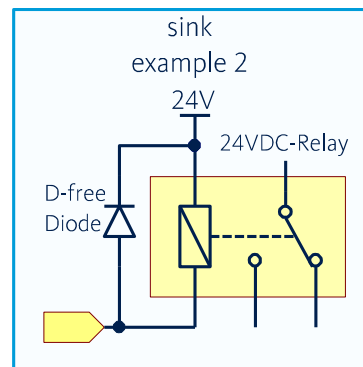
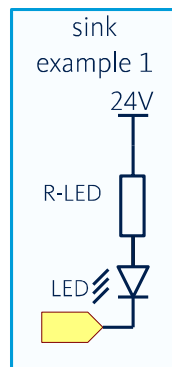
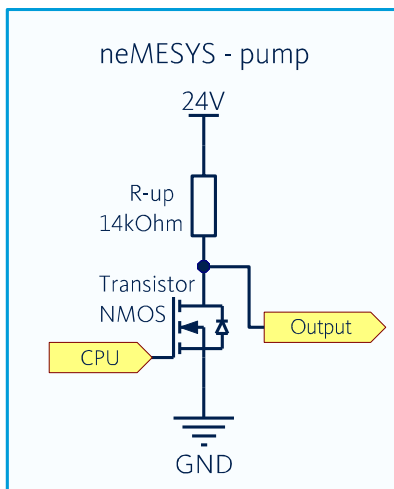



6.6 CAN-Bus Termination

The CAN-Bus must be terminated on both ends with a 120 Ω termination resistor.

6.7 Switching the Integrated Valve

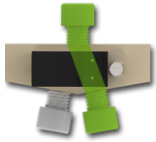
The integrated valve is switched by digital outputs 1 and 2. Switching of the valve is done through digital output 2. Digital output 1 can be used to lower the voltage during the activated state in order to prevent the valve from heating up due to the coil. The following logic table shows the relevant valve conditions for all possible signal combinations of digital outputs 1 and 2.

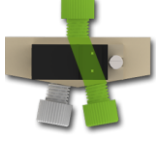
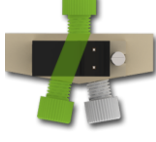
DIGOUT 1 "VALVE VOLTAGE"	DIGOUT 1 "VALVE SWITCHING"	COIL	LED	VALVE STATE
0	0	off	off	Outlet open 
0	1	Voltage lowered	less bright	Inlet remains open 
1	0	off	off	Outlet open 
1	1	Voltage 24 V	bright	Inlet opens 

7 Cable Set

7.1 Power Cable

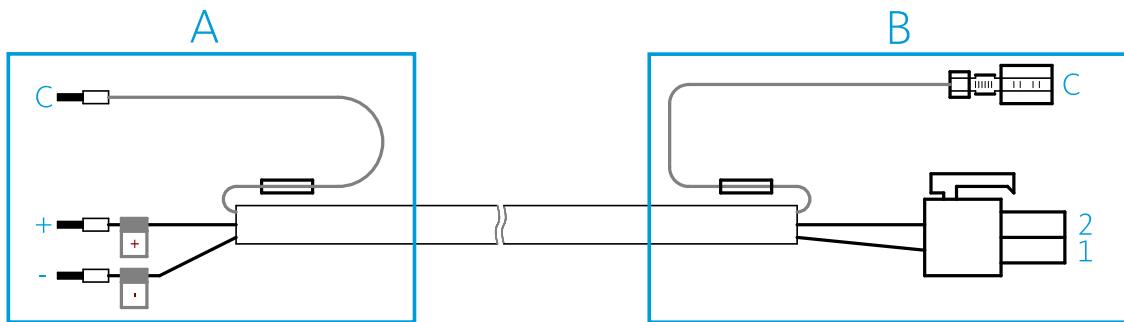

PINS SIDE A	SIGNAL	PINS SIDE B
-	Ground – Power GND	1
+	Supply voltage +24 VDC	2
C	Shield	C

TECHNICAL DATA

Cable size	2 x 1,5 mm ²
Side A	Cable end sleeves 1,5 mm ²
Side B	Molex Mini-Fit Jr. Female Connector 39012020 Molex Mini-Fit Jr. Female Crimp Terminal

7.2 Power Connection Cable

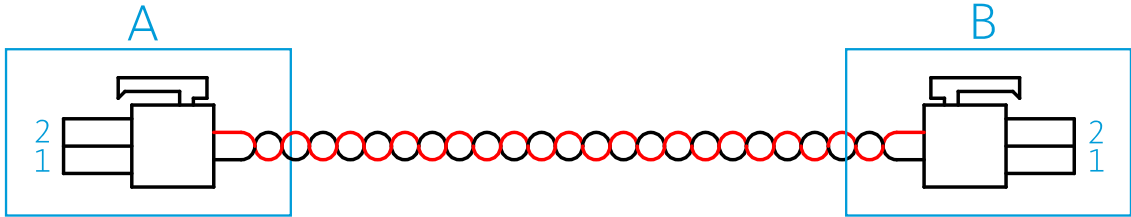

PINS SIDE A	SIGNAL	PINS SIDE B
1	Ground – Power GND	1
2	Supply voltage +24 VDC	2

TECHNICAL DATA	
Cable size	2 x 1,3 mm ²
Side A	Molex Mini-Fit Jr. 39-01-2020 Molex Mini-Fit Jr. crimp contact socket 444-76-xxxx
Side B	Molex Mini-Fit Jr. 39-01-2020 Molex Mini-Fit Jr. crimp contact socket 444-76-xxxx

7.3 CAN Cable (terminated D-Sub Socket)

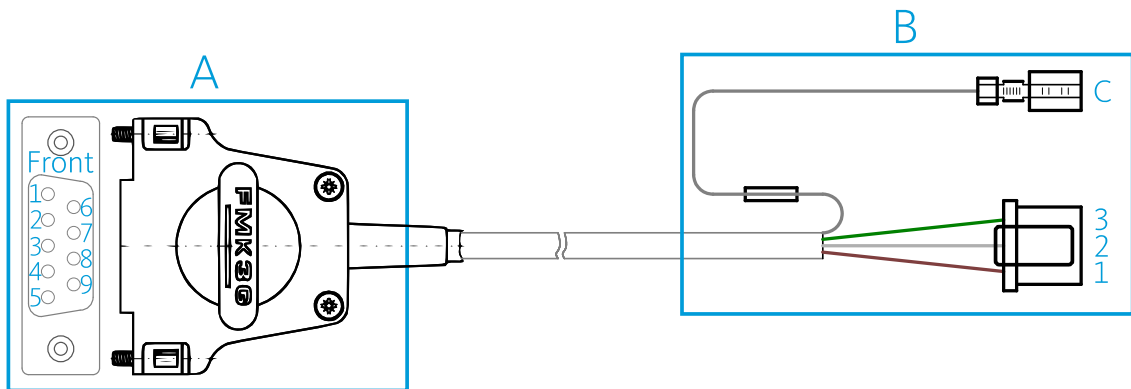

PINS SIDE A	SIGNAL	PINS SIDE B
Housing	CAN shield	C
3	CAN GND	3
2	CAN low	2
7	CAN high	1

TECHNICAL DATA

Cable size	3 x 0,125 mm ² , twisted pair, shielded
Side A	D-Sub socket DIN 41652, 9-pole type, with attachment screws 120 Ω resistor between CAN high (7) und CAN low (2)
Side B	3-pole socket JST XAP-03V-1



IMPORTANT. The socket contains a 120 Ω resistor placed between CAN high and CAN low, acting as a CAN-bus termination.

7.4 CAN Cable (D-Sub Plug)

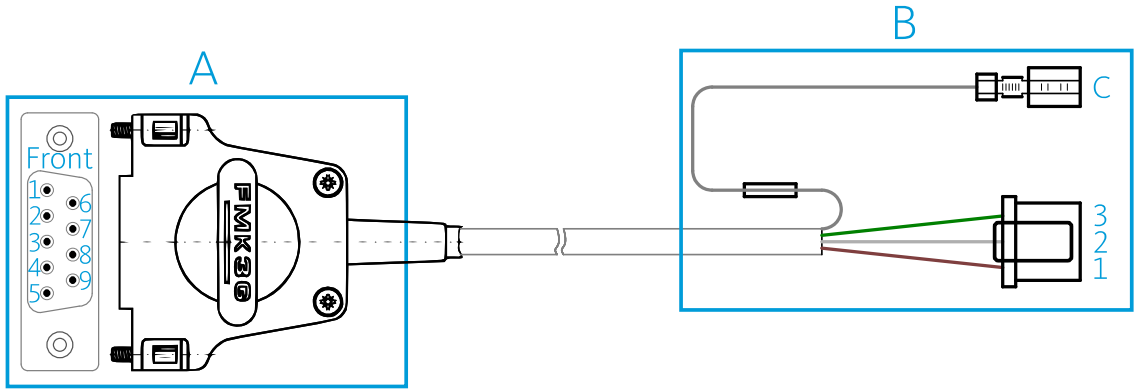

PINS SIDE A	SIGNAL	PINS SIDE B
Housing	CAN shield	C
3	CAN GND	3
2	CAN low	2
7	CAN high	1

TECHNICAL DATA	
Cable size	3 x 0,125 mm ² , twisted pair, shielded
Side A	D-Sub plug DIN 41652, 9-pole type, with attachment screws
Side B	3-pole socket JST XAP-03V-1

7.5 CAN Connection Cable

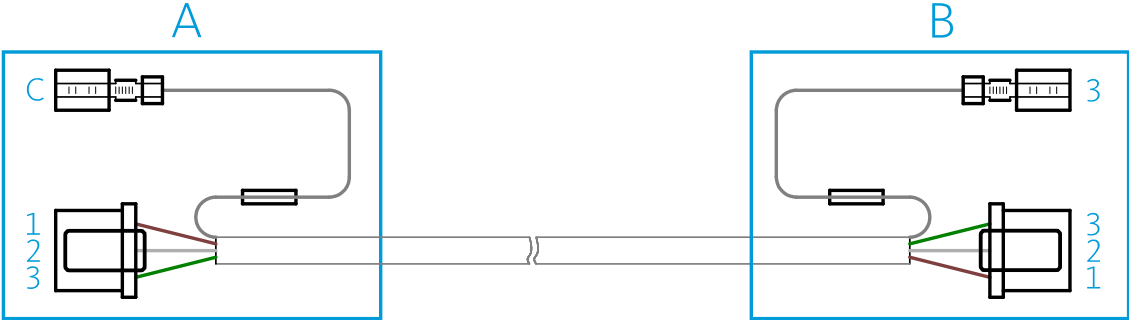

PINS SIDE A	SIGNAL	PINS SIDE B
1	CAN high	1
2	CAN low	2
3	CAN GND	3
C	CAN shield	C

TECHNICAL DATA	
Cable size	3 x 0,125 mm ² , twisted pair, shielded
Side A	3-pole socket JST XAP-03V-1
Side B	3-pole socket JST XAP-03V-1

7.6 CAN Terminator

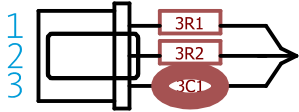

PINS SIDE A	SIGNAL	PINS SIDE B
1	CAN high	1
2	CAN low	2
3	CAN GND	3

TECHNICAL DATA	
Termination	120 Ω resistor between CAN high (1) und CAN low (2)
Plug connector	3-pole socket JST XAP-03V-1

7.7 RS-232 Cable (D-Sub Socket)

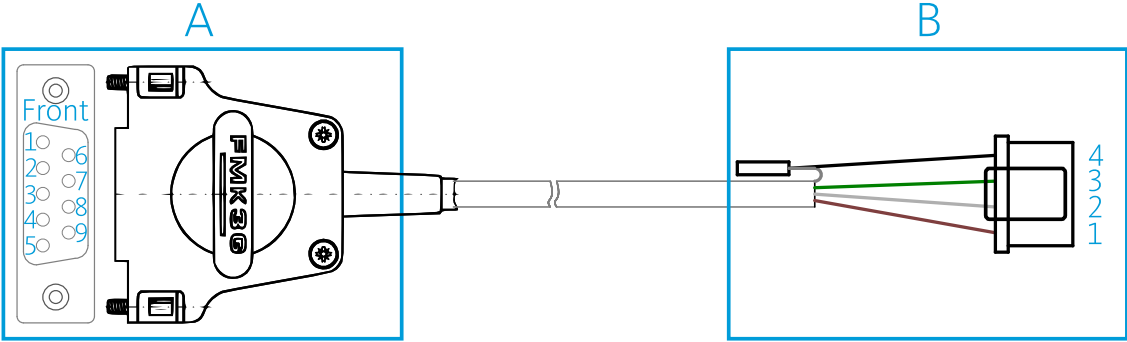

PINS SIDE A	SIGNAL	PINS SIDE B
Housing	Shield	4
5	Ground	3
2	neMESYS TxD	2
3	neMESYS RxD	1

TECHNICAL DATA	
Cable size	3 x 0,125 mm ² , twisted pair, shielded
Side A	D-Sub plug DIN 41652, 9-pole type, with attachment screws
Side B	4-pole type socket JST XAP-04V-1

7.8 USB-to-CAN Adapter

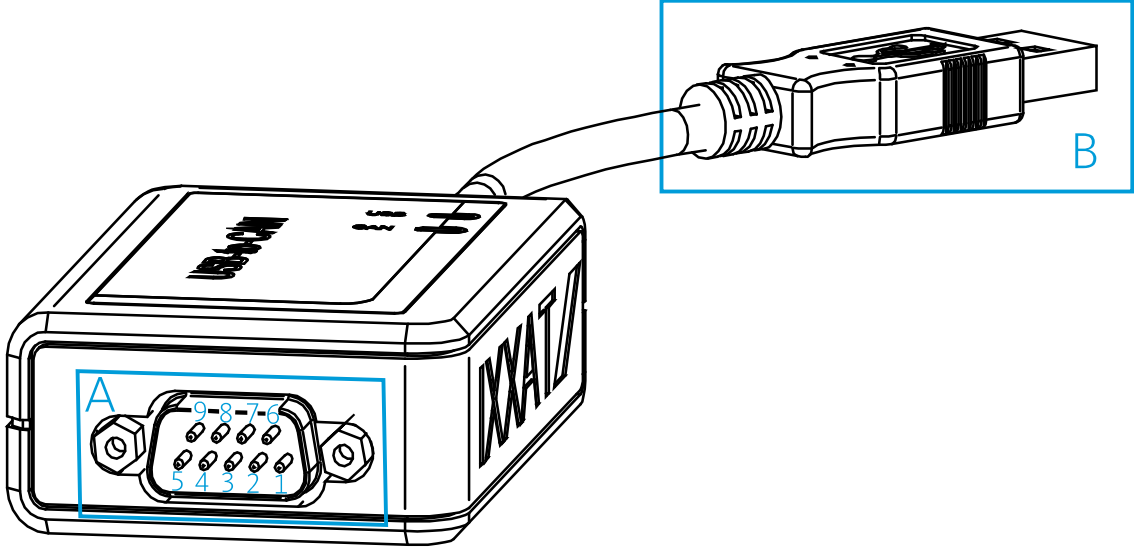

PINS SIDE A	SIGNAL	PINS SIDE B
Housing	CAN shield	USB type A
3	Ground	
2	CAN low	
7	CAN high	

TECHNICAL DATA	
Side A	D-Sub plug DIN 41652, 9-pole type, with attachment screws
Side B	USB type A

8 Setup & Cable Connection

8.1 Mechanical Setup

Use the four holes with a cylindrical depression at the corners of the base plate (see section 3.5 for the dimensional drawings of the pumps) to mount the neMESYS OEM 160 or neMESYS OEM 210 syringe pumps in the cutout of your device. Use M4 Allen screws according to DIN 912 for attachment.

8.2 Introduction to Cable Connection

Two different cable connections are required for installing neMESYS OEM 160 or neMESYS OEM 210 syringe pumps:

1. Connection of the first module to the power supply and the controller (PLC, PC).
2. Connecting the power supply and data line from one module to the next.

Perform the steps described below to connect your devices.

8.3 Step 1 – Connecting the Power Cable

Connect the power cable (see 7.1) to the plug connector J1 of the first syringe pump. Connect the other end of the cable to your power supply (+24 VDC). The required output current depends on the load and is governed by the number of connected devices. The typical current draw of a device is approximately 0.3 A. Short term peak current is about 0.6 A.

8.4 Step 2 – Data Connection

Data connection to the PC can be established through RS-232 or CAN bus. The cable connection for both connection types is described in the following sections. Use the section relevant to your type of connection.

8.4.1 Data Connection through CAN

You may choose from two connection options to connect neMESYS OEM 160 or neMESYS OEM 210 modules through CAN.

Option 1 – If you use neMESYS pumps exclusively and if no CAN bus is available or if you would like to connect the pumps directly to a PC using CAN, please connect the CAN cable (terminated D-Sub socket) (see 7.3) to CAN interface J3 of the first neMESYS OEM module. Then connect the D-Sub socket of the cable directly to the respective plug of the USB-to-CAN adapter.

Option 2 – If you want to integrate the neMESYS pumps into an existing CAN bus, please use the CAN cable (D-Sub plug) (see 7.4). Connect the cable to CAN interface J3 of the first neMESYS OEM module. Then connect the D-Sub plug to your existing CAN bus.



IMPORTANT. The CAN cable (terminated D-Sub socket) (see 7.3) already contains a 120 Ω bus termination resistor to terminate one side of the CAN bus. When using the CAN cable (D-Sub plug) (see 7.4), you have to establish the termination yourself (see CAN terminator 7.6).

8.4.2 Data Connection through RS-232

Connect the RS-232 cable (D-Sub socket) (see 7.7) to RS-232 connection J5 of the first neMESYS OEM module. Connect the 9-pole D-Sub socket at the other end of the cable to the respective plug connector of your controller (PC, PLC).

8.5 Step 3 – Power Supply of Additional Modules

Connect the end of the power connection cable (see 7.2) to power connector J2 (voltage output) of the already connected syringe pump. Connect the other end to power connector J1 (voltage input) of the next module in your setup. In this way you can supply power to every additional module.

8.6 Step 4 – Data Connection to Additional Modules

Use the CAN connection cable (see 7.5) to connect the data bus to additional neMESYS OEM 160 or neMESYS OEM 210 syringe pumps. Connect CAN connector J4 (signal output) of the first module to CAN connector J3 (signal input) of the next module. The individual elements of a CAN network should

be arranged electrically in line. Using the CAN connection cables you can route the internal CAN bus in a line structure from one module to the next.

8.7 Step 5 – CAN Bus Termination

CAN bus lines must be terminated on both ends using a 120 Ω resistor. You can do this very simply with the neMESYS OEM CAN termination plug (see 7.6).

If a neMESYS OEM 160 or neMESYS OEM 210 syringe pump is the first device in your CAN network, insert the CAN terminator into CAN connector J3 (signal input). If you use the CAN cable (terminated D-Sub socket) (see 7.3) this will not be necessary because the resistor is already integrated into the cable's D-Sub socket. If a neMESYS OEM 160 or neMESYS OEM 210 syringe pump is the last module in your CAN network, insert the CAN terminator into CAN connector J4 (signal output) of this module.

9 Maintenance and Care

The syringe pumps are maintenance-free when used correctly. However, should problems arise that you cannot resolve yourself, or which require opening the device please contact CETONI GmbH to arrange further action. The device may only be opened by CETONI GmbH or by authorized personnel. Otherwise the guarantee and warranty claim will void.

Wipe the unit with a damp (not wet) cloth, so that no liquid can drip into the device. For tough dirt you also can use a little detergent or alcohol.

10 Disposal

Please send your old devices back to CETONI GmbH. We will take care of proper disposal pursuant to the relevant laws and regulations.

Before you send a device back to CETONI, please decontaminate it, if required, and add a completed decontamination declaration to your shipment.